

Functioning safety of thru-beam, retro-reflective and diffuse sensors depends considerably on alignment. In case of thru-beam sensors the transmitter and the receiver must be adjusted to each other. In case of retro-reflective sensors resp. Diffuse sensors these must be aligned to the reflector resp. to the object. Moreover, retro-reflective sensors require the sensibility to be adjusted by means of the incorporated potentiometer. Thus the desired reflection by the object is inhibited in the near range. Adjustment is facilitated by means of a 2-colour LED (red/green) as well as by 2 additional green LEDs.

If no IR radiation reaches the sensor, all 3 mm LEDs remain dark. Already slight transmitter radiation induces the sensor to switch. On switching the first 3 mm LED starts blinking in red. Thus following is indicated: There is radiation, however it is not sufficient for safe operation. Units with a contamination control output indicate trouble when this state of operation lasts longer than 200 ms. With increasing radiation the first LED changes from blinking in red to green. Now safe operation is guaranteed. On alignment you should try to achieve that the second and third green LED give light as well, in order to obtain optimum reserve for functioning.

Adjustment is facilitated by using a swivel stand with two axles (HM 1). First align the sensor roughly until indication is effected. Stop the horizontal axle in this position and set the vertical one to max. indication. Then stop vertical axle and set horizontal one to max. indication. If required repeat this procedure until optimum adjustment is achieved.

Thru-beam sensors LA_ (receiver)

The receiver switches as soon as IR radiation of the transmitter arrives.

Normally-close: large LED (red) gives light

Normally-open: large LED (red) stops giving light

By means of the electronic adjusting unit align the receiver exactly to the transmitter: When the sensor swivels, the green LEDs reach their max. indication in the center of the optic axis.

ATTENTION: In case of large distances between transmitting and receiver it is not possible to get all LEDs giving light.

Retro-reflective sensors LR_ Diffuse sensors LT_

The retro-reflective sensor switches as soon as IR radiation of the reflector arrives.

Normally-close: large LED (red) gives light

Normally-open: large LED (red) stops giving light.

The diffuse sensor works without reflector. It switches as soon as IR radiation reflected by the object arrives.

Normally-close: large LED (red) stops giving light

Normally-open: large LED (red) gives light

By means of the electronic adjusting unit align the sensor exactly. When the sensor swivels, the green LEDs reach their max. indication in the center of the optic axis.

If required the approx. point of operation of retro-reflective sensors is to be determined by means of the potentiometer. The position of the potentiometer has different meanings dependent on the application: If in case of max. position of the poti (at the right) all green LEDs give light, max. protection against contamination of sensor and reflector is achieved – however in the near range of the sensor there is danger of malfunction because of possible reflection by the object itself. Therefore the point of operation is to be shifted by turning the potentiometer to the left until only the 2-colour LED gives green light.

If safety in operation is not longer achieved, e. g. by contamination, the LED changes from green to red blinking.

NOTE: If the sensor does not work at max. position of potentiometer (at the right), you must find out when the sensor begins working by slight turning to the left.

Monitoring of a walking beam furnace

Applied: Piros true-beam sensor
LAA 201.1 D (transmitter)

LSD 201.13 G with fibre optic cable and optic
OAC 204 (receiver)

HL 133 (furnace window)



The Piros light barrier controls the interior as to position and size of the rolled stock.

In case of this installation the pipe going into the furnace is stopped in front of the stop by means of the light barrier signal and occupation of the walking beam is checked.

The Proxitron furnace window prevents flames from leaving the furnace by means of overpressure.



Factory photos: Mannesmannröhren-Werke

Monitoring of a strip roller path

Applied: Piros light grid
LAH 050.1 (transmitter)

LSH 050.18 (receiver)

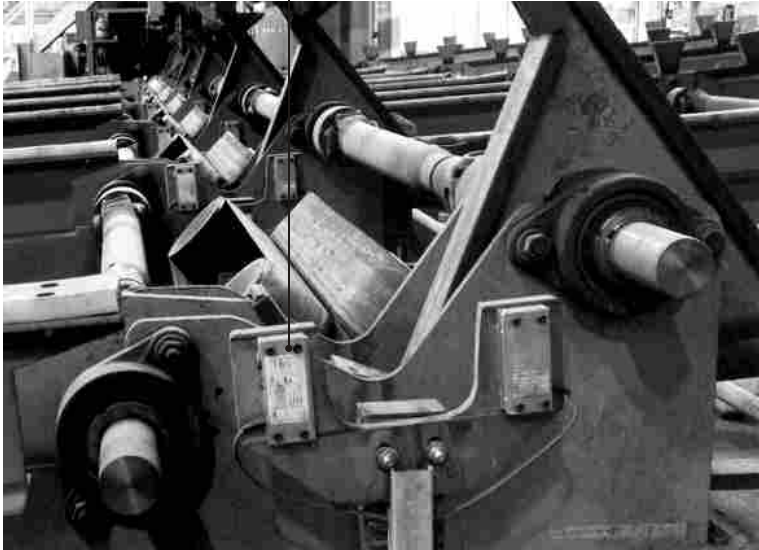

Piros light grid support the rough measuring of pipe length. They supply reproducible signals for beginning of the pipe and its end independent from the pipe diameter.

Occupation of the strip roller path is monitoring by inductive proximity switches beneath the conveyor belts.

If a pipe is detected by the light grid, the light grid sets a counter to zero in the plant control. By means of a incremental rotary transmitter which accompanies the pipe exact length measuring to +/- 1mm is possible.



factory photos: Mannesmannröhren-Werke

The exactitude of measuring the lengths of pipes is influenced by the reproducibility of determining the first and the second pipe end. By means of the Piros light grid pipes are safely detected independent from varying pipe diameters, whereas in case of one-beam light barriers adjustment would always be required. Simple starting-up, high exactitude in repetition and safe integrated fault control were requested as precondition for reversing operation of a pipe adjustment.

The light grid LH operates as one-way light barrier with 10 individual paths at the spacing of 8 mm. The invisible infrared radiation between sender and receiver scans a height of 75 mm for entering material.

In connection with a barrier width of e. g. 1400 mm a supervised area of 75 mm x 1400 mm results.

In case of mode of operation 1 the smallest object which can safely be detected must have a diameter of 15 mm. Then outlet 1 (LED yellow) is activated by interrupting at least two neighbor paths. In case of this mode of operation outlet 2 (LED red) can be used as dirt indication: Outlet 2 opens with a delay of 1 second after interruption of one path and closes 10 ms after elimination of the trouble. For mode of operation 0 the object size must be at least 30 mm in diameter.

The output 1 can be switched over from light switching to dark switching (normally-closed / normally-open). Both outlets are short-circuit-proof and over-load-proof. If so the red and the yellow LED give intermittent light.

Notes: The receiver is synchronized by the wire colors yellow and beige for reproducibility's sake. These lines should be led on the shortest possible way.

For perfect functioning of the light grid exact alignment towards all directions is required. The green LED serves as adjustment help and lightens brightly as soon as the 10 paths are installed without any interruption.

Depending of the measuring frequency which is adjustable by the incorporated potentiometer the switching evaluates the number of the interrupted light pulses. Therefore for increasing the trouble safety a minimum measuring frequency is recommended as the case of application makes this possible.

Potentiometer and the switch for the modes of operation are installed behind a protective cap.

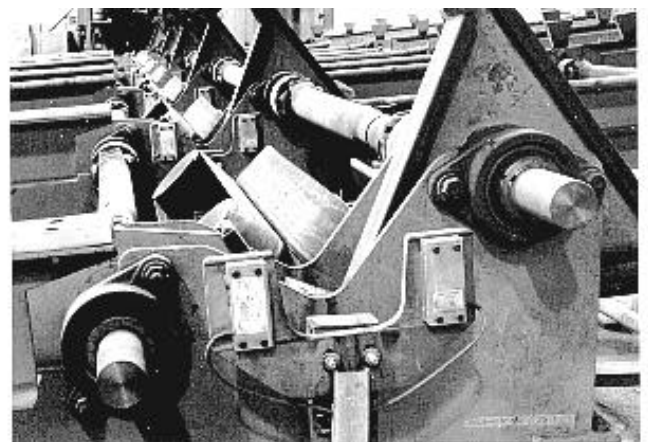
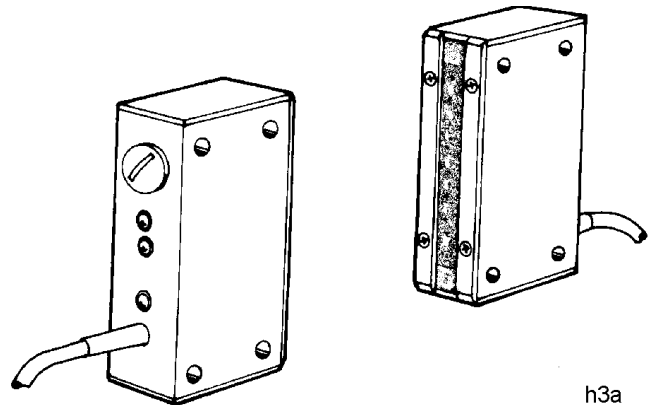

Works picture: Mannesmannröhren Werke

Technical Data

| Selection Table: | Sender | Receiver |
|------------------|------------------|-------------------|
| Type | LAH 050.1 | LSH 050.18 |
| Art.-No. | 5007 A | 5008 A |
| Voltage | 20 - 28 V DC | 20 - 28 V DC |
| Barrier width | 500 mm | 500 mm |
| Connection | 3 m cable | 1,5 m cable |

| Type | LAH 050.2 | LSH 050.28 |
|---------------|------------------------|--------------|
| Art.-No. | 5007 B | 5008 B |
| Voltage | 10 - 15 V DC | 10 - 15 V DC |
| Barrier width | 500 mm | 500 mm |
| Connection | 3 m cable | 1,5 m cable |
| | with cable-plug Binder | 5-Terminals |
| | | 7-Terminals |

| Type | LAH 140.1 | LSH 140.18 |
|---------------|--------------|--------------|
| Art.-No. | 5007C | 5008 C |
| Voltage | 20 - 28 V DC | 20 - 28 V DC |
| Barrier width | 1400 mm | 1400 mm |
| Connection | 3 m cable | 3 m cable |

| | |
|---|--|
| Barrier height | 75 mm |
| Number of paths | 10 |
| Spacing | 8 mm |
| Housing material | Aluminum |
| Enclosure rating | IP 67 |
| Ambient temperature | -25 to +70 °C |
| Current consumption | sender 100 mA receiver 30 mA |
| Ripple | max. 15% |
| Output 1 (operation) programmable | PNP n.o. / n.c. dark/bright switching |
| Output 2 (trouble indication) | PNP norm. closed bright switching |
| Constant current | 0 - 400 mA |
| Short-time load current | 2A / 10 ms 0,8 A / 100 ms |
| Short circuit protected | yes |
| Voltage drop | 2 V |
| Pulse frequency | 1000 Hz |
| Measuring frequency, adjustable (switching time, adjustable) | 10 upto 400 Hz (50 upto 1,25 ms) |
| Object size min., mode 1 | 15 mm Ø |
| Object size min., mode 0 | 30 mm Ø |
| Weight | |

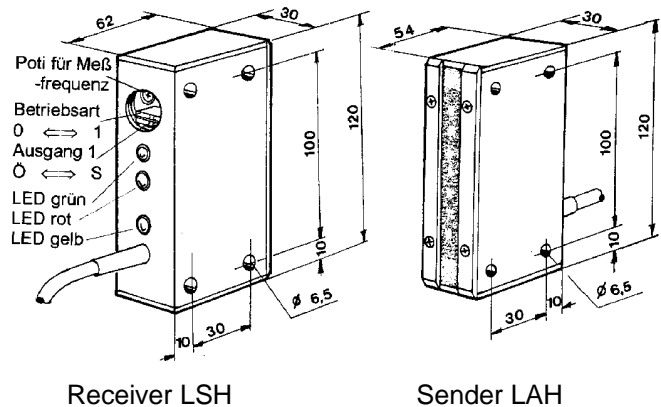
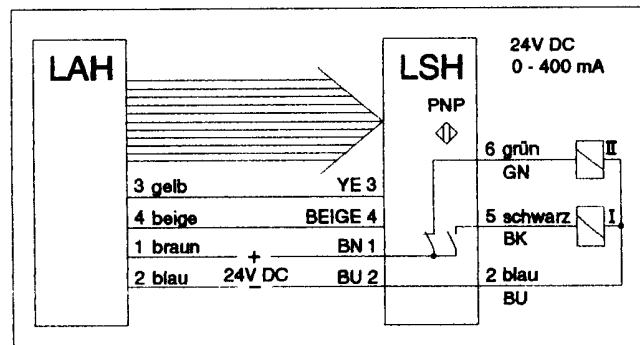

Diagram of Connections



Switching times

The switching output of the light grids is effected with time delay after an object entered the scanning area. This time delay consists of several components:

a: The grid consisting of 10 light barriers is cyclically pulsed with a frequency of approx. 1 kHz. (Each individual barrier sends a time-staggered light pulse of approx. 50 µs at a break of 950 µs.) Thus a systematic scanning error is produced between the time-random inlet/outlet from the grid and the electronic detection. This error can amount to upto 1 ms and can differ for each switching process.

b: Dependent on the fixed adjustment of the potentiometer for the safety factor (integrated filter) an additional delay results between electronic detection and switching output. This delay is nearly identical for the switching-on and the switching-off process and remains constant. When the potentiometer is turned to the clockwise end, the delay is approx. 1,5 - 2 ms (lowest trouble safety). When the potentiometer is turned to the other end, the delay is approx. 22ms (highest trouble safety).

c: Compared with the a.m. times the switching slopes of the quick final stages of semi-conductors are not relevant.

For years Proxitron sensors for material pursuance have proved to be successful in hard applications in steel mills. Object identification within channels and annealing furnaces is rendered even more difficult because of long measuring paths at high background radiation. Arrangements with Piros light barriers of series LAA 201 have proved to be reliable for these applications.

The basic version LAA 201 (sender) with LSD 201 (receiver) reaches a barrier widths of 25 m. In the sketch the receiver consists of a transmission path with optic (OAC 204) and a fibre optic cable of 5 m length (LLK 5). Thus the receiver (LSD 201) can be installed beyond the warm furnace area.

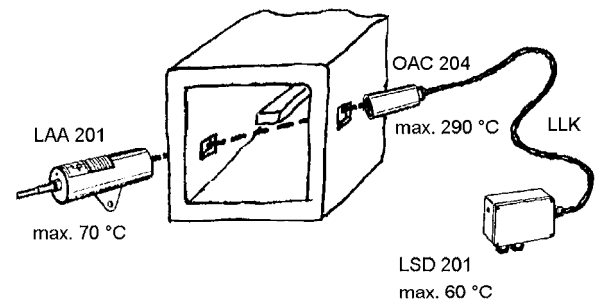

Technical Data

| | |
|---------------------|---------------------|
| Type | LAA 201.1 DM |
| Art.-Nr. | 5004P |
| Function | transmitter |
| Range | 25 m max. |
| Supply voltage | 24 V DC |
| Current absorbed | approx. 30 mA |
| Ambient temperature | -25 to +70 °C |
| Protection class | IP 67 |
| Connection | terminals |
| Function display | LED |
| Housing material | stainless steel |

| | |
|--|---|
| Type | LSD 201.13 G MD |
| Art.-Nr. | 5005E |
| Function | receiver |
| Range | 25 m max. |
| Output | PNP n. o. closed by beam-interruption |
| Supply voltage | 24 V DC |
| Current absorbed | approx. 35 mA |
| Load current max. | 0-400 mA |
| Short circuit protection | yes, pulsing |
| Operating frequency | 100 Hz |
| Ambient temperature | -25 to +60 °C OAC / LLK -40 to +290 °C |
| Protection class | IP 67 |
| Connection | terminals |
| Function display | LED |
| Adjusting device and contamination control | LED |
| Housing material | aluminium |

Diagram of Connections

Transmitter LAA 201.1 DM

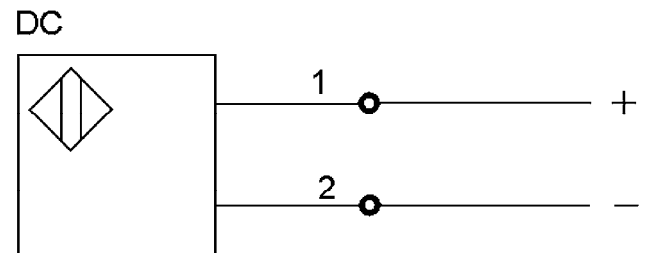

Receiver LSD 201.13 G MD

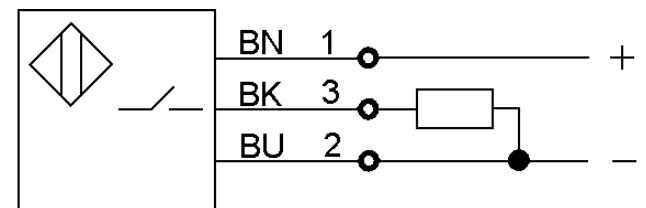

Adjusting Device LSD 201

The electronic adjusting device of Proxitron thru-beam sensor receivers serves for exact alignment to the transmitter. When the thru-beam sensor swivels, the green LEDs reach their max. indication in the centre of the optic axis. If no IR-radiation from the transmitter reaches the receiver, all three 3 mm LEDs remain dark. Already slight transmitter radiation incoming causes the receiver to switch.

Normally-close: large LED (red) gives light.

Normally-open: large LED (red) stops to give light.

In the moment of switching the lower 3 mm LED starts blinking in red. Thus it indicates: there is radiation, but it is not sufficient for safe operation. With increasing radiation the lower LED changes from blinking in red to green light. Now safe operation is guaranteed. During alignment it should be tried to induce the second and third green LED to show green as well, in order to reach max. possible safety margin for operation.

Transmitter LAA 201.1 DM

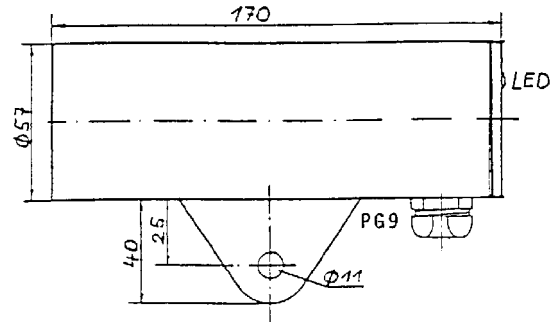

Receiver LSD 201.13 G DM

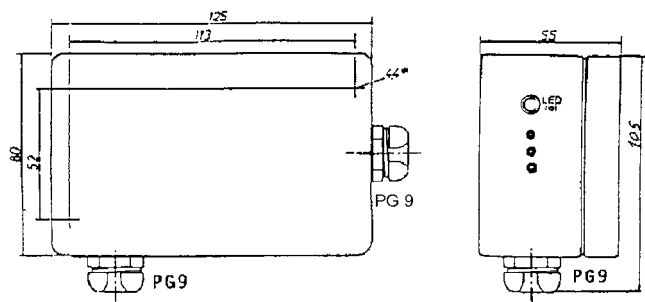

Optic for receiver OAC 204 / LLK

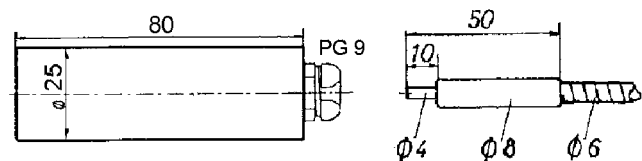

For years Proxitron sensors for material pursuance have proved to be successful in hard applications in steel mills. Object identification within channels and annealing furnaces is rendered even more difficult because of long measuring paths at high background radiation. Arrangements with Piros light barriers of series LAD 201 have proved to be reliable for these applications.

The basic version LAD 201 (sender) with LSD 201 (receiver) reaches a barrier widths of 25 m. In the sketch the receiver consists of a transmission path with optic (OAC 204) and a fibre optic cable of 4 m length (LLK 4). Thus the receiver (LSD 201) can be installed beyond the warm furnace area.

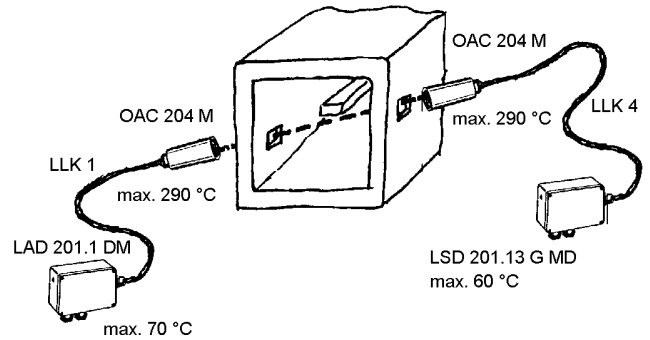

Technical Data

| | |
|---------------------|---------------------|
| Type | LAD 201.1 DM |
| Art.-Nr. | 5004Q |
| Function | transmitter |
| Range | 25 m max. |
| Supply voltage | 24 V DC |
| Current absorbed | approx. 30 mA |
| Ambient temperature | -25 to +70 °C |
| Protection class | IP 67 |
| Connection | terminals |
| Function display | LED |
| Housing material | aluminium |

| | |
|--|---|
| Type | LSD 201.13 G MD |
| Art.-Nr. | 5005E |
| Function | receiver |
| Range | 25 m max. |
| Output | PNP n. o. closed by beam-interruption |
| Supply voltage | 24 V DC |
| Current absorbed | approx. 35 mA |
| Load current max. | 0-400 mA |
| Short circuit protection | yes, pulsing |
| Operating frequency | 100 Hz |
| Ambient temperature | -25 to +60 °C OAC / LLK -40 to +290 °C |
| Protection class | IP 67 |
| Connection | terminals |
| Function display | LED |
| Adjusting device and contamination control | LED |
| Housing material | aluminium |

Diagram of Connections

Transmitter LAD 201.1 DM

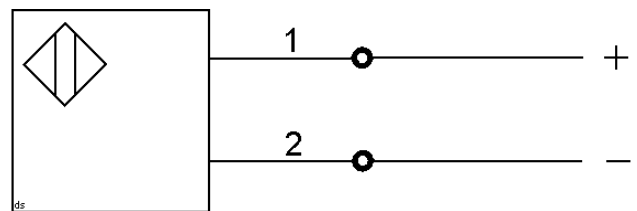

Receiver LSD 201.13 G MD

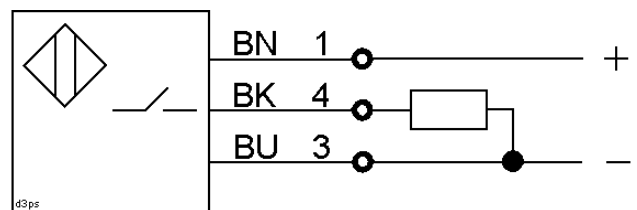

Adjusting Device LSD 201

The electronic adjusting device of Proxitron thru-beam sensor receivers serves for exact alignment to the transmitter. When the thru-beam sensor swivels, the green LEDs reach their max. indication in the centre of the optic axis. If no IR-radiation from the transmitter reaches the receiver, all three 3 mm LEDs remain dark. Already slight transmitter radiation incoming causes the receiver to switch.

Normally-close: large LED (red) gives light.

Normally-open: large LED (red) stops to give light.

In the moment of switching the lower 3 mm LED starts blinking in red. Thus it indicates: there is radiation, but it is not sufficient for safe operation. With increasing radiation the lower LED changes from blinking in red to green light. Now safe operation is guaranteed. During alignment it should be tried to induce the second and third green LED to show green as well, in order to reach max. possible safety margin for operation.

Transmitter LAD 201.1 DM

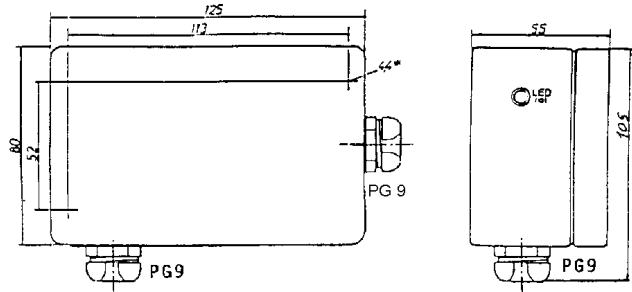

Receiver LSD 201.13 G DM

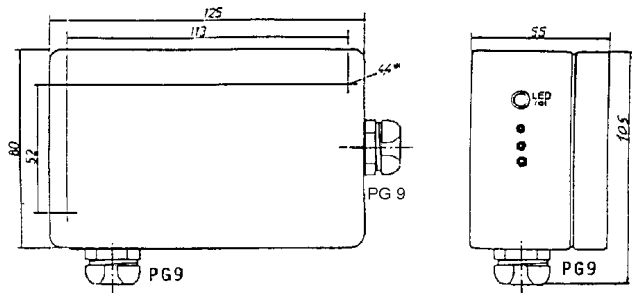

Optic OAC 204 / LLK

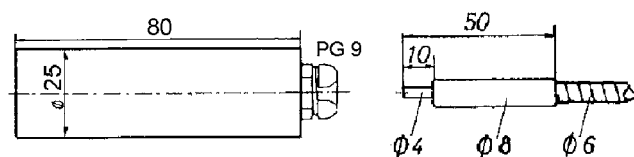

Piros thru-beam sensor for material monitoring and object detection in steel and rolling mills.

Robust stainless steel design with LED indication

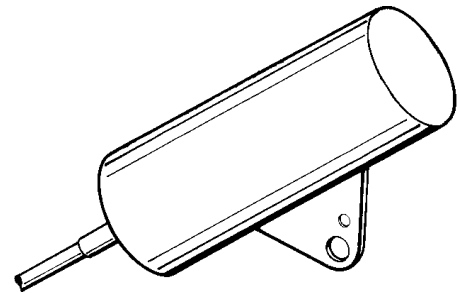

Technical data

| | |
|------------------------|---------------------|
| Type | LAA 201.1 |
| Art.-No. | 5004N |
| Usable with receiver | LSA 201 LSB 201 |
| Range | 25 m max. |
| Function | transmitter |
| Supply voltage | 24 V DC |
| Ripple voltage | 15 % max. |
| Current absorbed | approx. 30 mA |
| Ambient temperature | -20 ... +80°C |
| Protection class | IP 67 |
| Connection | 2m POKT-Therm cable |
| Supply voltage display | LED |
| Housing material | stainless steel |

Diagram of connections

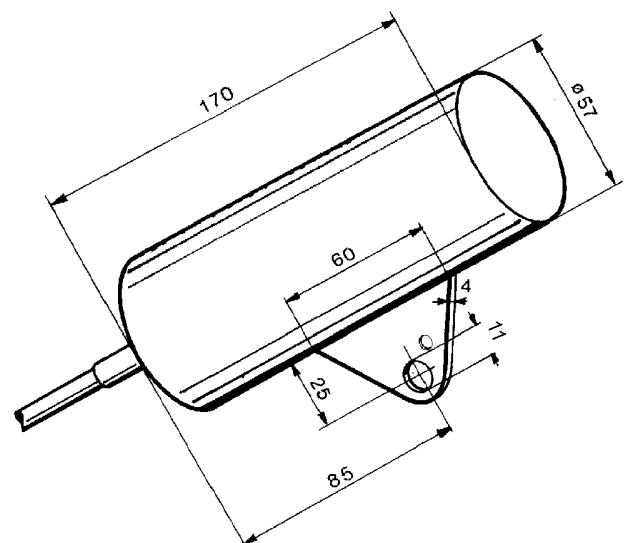
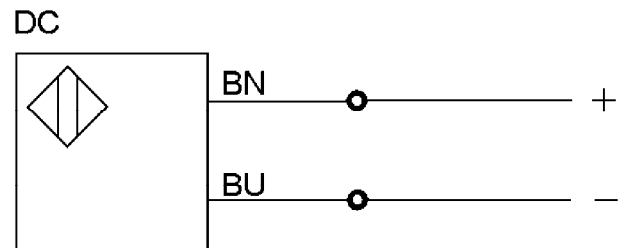

Piros thru-beam sensor for material monitoring and object detection in steel and rolling mills.

Robust stainless steel design with electronic adjusting aid and contamination control by LED indication

Technical data

| | |
|--|--|
| Type | LSA 201.18 G |
| Art.-No. | 5010D |
| Usable with transmitter | LAA 201 LAB 201 |
| Output | closed by beam-interruption PNP n. o. opened by beam-interruption PNP n. c. |
| Range | 25 m |
| Function | receiver |
| Supply voltage | 24 V DC |
| Ripple voltage | 15 % max. |
| Load current max. | 0 - 400 mA |
| Short-time load current | 2 A / 10 ms 0,8 A / 100 ms |
| Short circuit protection | yes, pulsing |
| Current absorbed | approx. 35 mA |
| Operating frequency | 100 Hz |
| Ambient temperature | -20 to +80 °C |
| Protection class | IP 67 |
| Connection | 2m POKT-Therm cable |
| Function display | LED Ø 5mm |
| Adjusting device and contamination control | 3 LED Ø 3mm |
| Housing material | stainless steel |

The electronic adjusting device of Proxitron thru-beam sensor receivers serves for exact alignment to the transmitter. When the thru-beam sensor swivels, the green LEDs reach their max. indication in the centre of the optic axis. If no IR-radiation from the transmitter reaches the receiver, all three 3 mm LEDs remain dark. Already slight transmitter radiation incoming causes the receiver to switch. Normally-close: large LED (red) gives light. Normally-open: large LED (red) stops to give light. In the moment of switching the left 3 mm LED starts blinking in red. Thus it indicates: there is radiation, but it is not sufficient for safe operation. With increasing radiation the left LED changes from blinking in red to green light. Now safe operation is guaranteed. During alignment it should be tried to induce the second and third green LED to show green as well, in order to reach max. possible safety margin for operation.

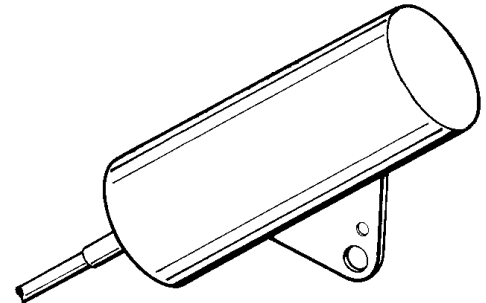
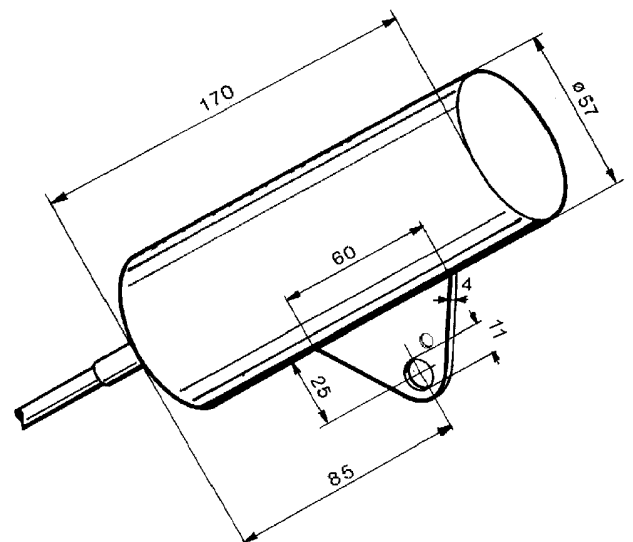
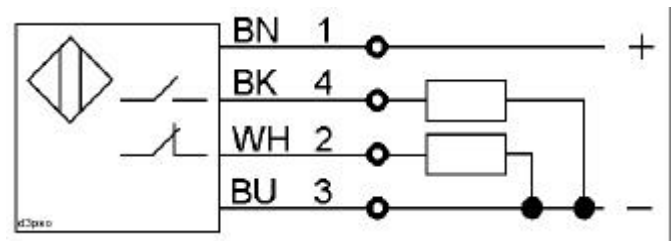
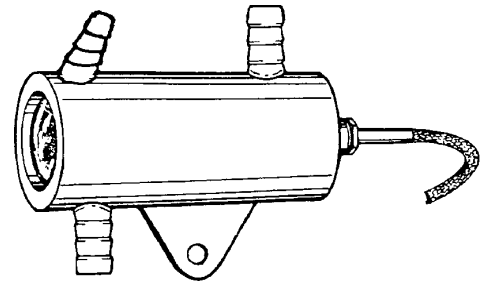

Diagram of Connections



Piros thru-beam sensor with cooling shell for material monitoring and object detection in steel and rolling mills.

Robust stainless steel design with electronic adjusting aid and contamination control by LED indication



Technical Data

| | |
|------------------------|--|
| Type | LAB 201.5 L |
| Art.-No. | 5002C |
| Usable with receiver | LSA 201 LSB 201 |
| Range | 25 m max. |
| Function | transmitter |
| Supply voltage | 115 V AC +/- 15 % |
| Power frequency | 45 - 65 Hz |
| Current absorbed | approx. 40 mA |
| Ambient temperature | -20 ... +80°C without cooling |
| Protection class | IP 67 |
| Connection | 2 m POKT-Therm cable with G 3/4" flexible tube connection |
| Supply voltage display | LED |
| Housing | stainless steel with cooling jacket |

Diagram of Connections

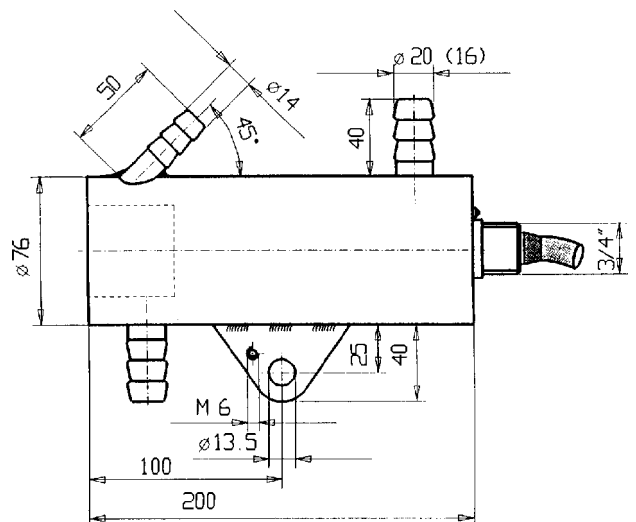
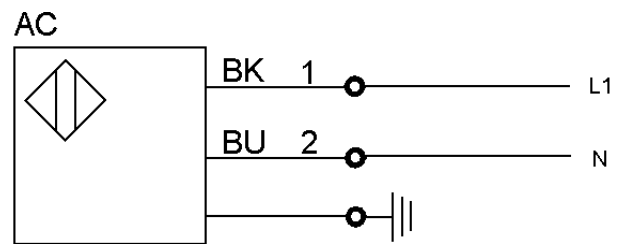

Piros thru-beam sensor for material monitoring and object detection in steel and rolling mills.

Robust stainless steel design with electronic adjusting aid and contamination control by LED indication

Technical data

| | |
|---|---|
| Type | LSB 201.53 LK |
| Art.-No. | 5003L |
| Usable with transmitter | LAA 201 LAB 201 |
| Output closed by beam-interruption | normally open |
| Range | 25 m |
| Function | receiver |
| Supply voltage | 115 V AC $\pm 15\%$ |
| Power frequency | 45 – 65 Hz |
| Load current max. | 0 - 400 mA |
| Short-time load current | 2 A / 10 ms 0,8 A / 100 ms |
| Short circuit protection | yes |
| Current absorbed | approx. 40 mA |
| Operating frequency | 25 Hz |
| Ambient temperature | -20 to +80 °C without cooling |
| Protection class | IP 67 |
| Connection | 2 m steel armoured silicone cable with G 3/4" flexible tube connection |
| Function display | LED \varnothing 5mm |
| Adjusting device and contamination control | 3 LED \varnothing 3mm |
| Housing material | stainless steel with cooling jacket |

The electronic adjusting device of Proxitron thru-beam sensor receivers serves for exact alignment to the transmitter. When the thru-beam sensor swivels, the green LEDs reach their max. indication in the centre of the optic axis. If no IR-radiation from the transmitter reaches the receiver, all three 3 mm LEDs remain dark. Already slight transmitter radiation incoming causes the receiver to switch. Normally-close: large LED (red) gives light. Normally-open: large LED (red) stops to give light. In the moment of switching the left 3 mm LED starts blinking in red. Thus it indicates: there is radiation, but it is not sufficient for safe operation. With increasing radiation the left LED changes from blinking in red to green light. Now safe operation is guaranteed. During alignment it should be tried to induce the second and third green LED to show green as well, in order to reach max. possible safety margin for operation.

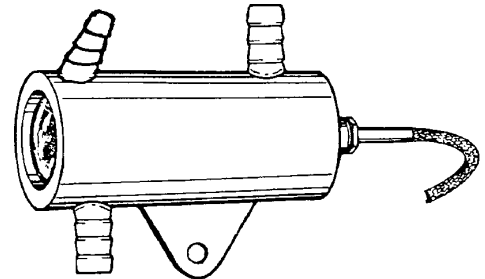
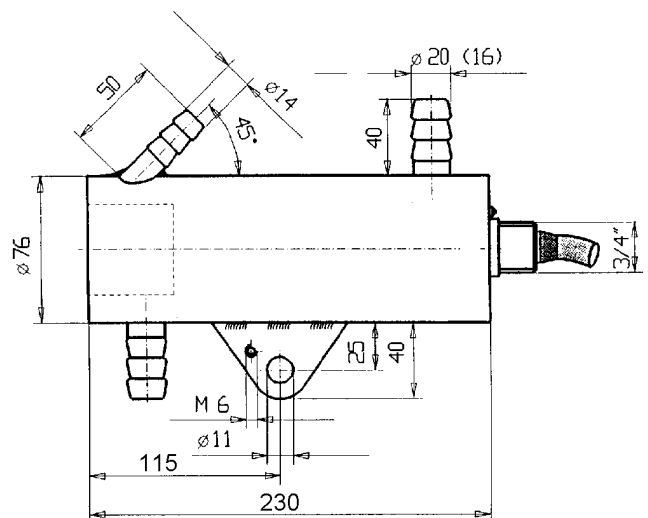
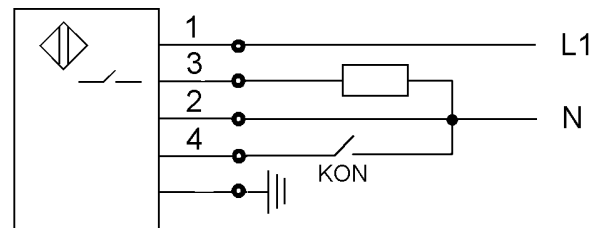

Diagram of Connections



Piros retro-reflective sensor with for material monitoring and object detection in steel and rolling mills.

Robust stainless steel design with electronic adjusting aid and contamination control by LED indication

Technical data

| | | |
|--|--|------------------------|
| Type | LRA 121.18 G | |
| Art.-No. | 5001U | |
| Output | closed by beam-interruption opened by beam-interruption | PNP n. o. PNP n. c. |
| Range | 12 m | |
| Supply voltage | 24 V DC | |
| Ripple voltage | 15 % max. | |
| Load current max. | 0 - 400 mA | |
| Short-time load current | 2 A / 10 ms 0,8 A / 100 ms | |
| Short circuit protection | yes, pulsing | |
| Voltage drop | 2 V | |
| Operating frequency | 100 Hz | |
| Ambient temperature | -20 to +75 °C | |
| Protection class | IP 67 | |
| Connection | 2m POKT-Therm cable | |
| Function display | LED Ø 5mm | |
| Adjusting device and contamination control | 3 LED Ø 3mm | |
| Housing material | stainless steel | |

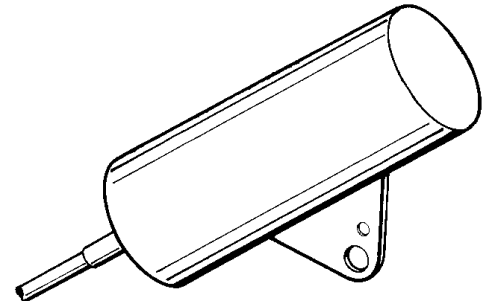
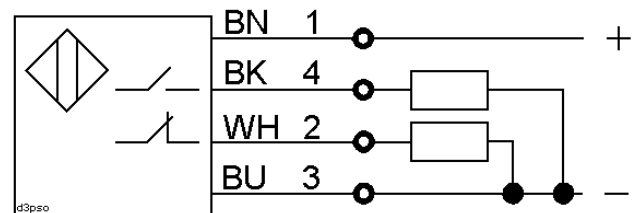

Diagram of Connections



By means of the electronic adjusting unit align the sensor exactly. When the sensor swivels, the green LEDs reach their max. indication in the center of the optic axis.

If required the approx. point of operation of retro-reflective sensors is to be determined by means of the potentiometer. The position of the potentiometer has different meanings dependent on the application: If in case of max. position of the poti (at the right) all green LEDs give light, max. protection against contamination of sensor and reflector is achieved – however in the near range of the sensor there is danger of malfunction because of possible reflection by the object itself. Therefore the point of operation is to be shifted by turning the potentiometer to the left until only the 2-colour LED gives green light.

If safety in operation is not longer achieved, e. g. by contamination, the LED changes from green to red blinking.

NOTE: If the sensor does not work at max. position of potentiometer (at the right), you must find out when the sensor begins working by slight turning to the left.

