

R-Series EtherCAT

Temposonics-RP and RH
Measuring length 25 - 7600 mm



**Advanced Communication
... offers Multi-Position Measurement**

New: Diagnostic LED



- Rugged Industrial Sensor
- Linear and Absolute Measurement
- LEDs for Sensor Diagnostics
- Contactless Sensing with Highest Durability
- Superior Accuracy: Linearity better 0,01 %
- Resolution 5 µm
- Repeatability 0,001 %
- Direct EtherCAT Output: Displacement + Velocity with 5 Magnets
- Multi-Position measurement: Displacement with up to 20 Magnets

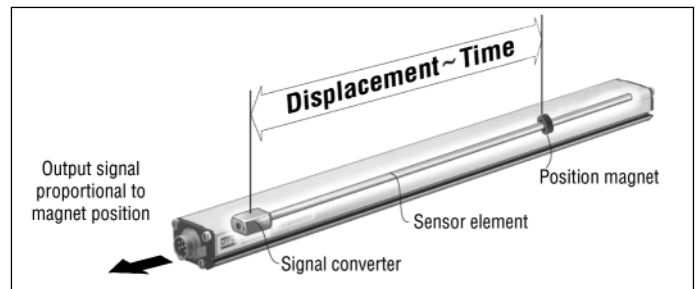

Magnetostriction	Form factor
------------------	-------------

The absolute **Temposonics®** linear position sensors are based on the MTS developed magnetostrictive measurement principle. That combines various magneto-mechanical effects and uses the physical height precise speed-measurement of an ultrasonic wave (torsion pulse in its sensor element) for position detecting. Sensor integrated signal processing transforms the measurements directly into market standard outputs. The contactless principle - an external movable magnet marks the position - eliminates the wear, noise and erroneous signal problems and guarantees the best durability without any recalibration.

The extremely robust sensor, ideal for continuous operation under harshest industrial conditions is completely modular in mechanic and electronic design.

- A profile or rod-shaped sensor housing protects the sensing element in which gives rise to the measurement signal.
- The sensor head accommodates the complete modular electronic interface with active signal conditioning. Double encapsulation ensures high operating safety and optimum EMC protection.
- The position transmitter, a permanent magnet - fixed at the mobile machine part - drives contactlessly over the sensor's stroke and starts measuring through the housing wall.

New...a sensor diagnostic display

Integrated LEDs (green/red) provide basic visual feedback for normal sensor operation and troubleshooting.

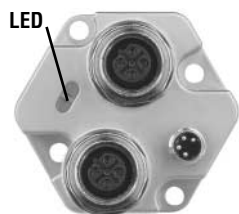

Grün	Rot	Bedeutung
Flashing	OUT	Normal function
Flashing	ON	Magnet not detected or Wrong quantity of magnets

Characteristics of the EtherCAT sensor

Sensor's output

- Position as an absolute value
- Velocity and direction of the drive
- Diagnostics (Status information)

The EtherCAT Interface

The sensor fulfils the requirements of the EtherCAT field-bus and can be connected as a slave to this bus system. EtherCAT is an open field-bus system which is based on the EtherNet technology (IEEE 802.3) with a high data rate, short response time and a good real-time performance, it is standardized in the IEC/PAS 62407 and it is part of the ISO 15745-4. The integration in the IEC 61158, IEC 61784 and IEC 61800-7 is in the way.

It is very easy to implement the Temposonics sensor with the EtherCAT interface into an EtherCAT field-bus system. The System-Manager (e. g. TwinCAT from Beckhoff) gets all the parameters of the sensor from the XML-file, which part of the delivery. There are no settings on the sensor.

Operation Mode

There are two versions available:

E101 1-5 magnet measurement

Measuring in parallel the position and velocities of up to 5 magnets.

The data telegram contains from each magnet:

- Position (32 bit)
- Velocity (32 bit)
- Long status information (16 bit)

E102 1-20 multi-magnet measurement

Measuring in parallel the positions of up to 20 magnets.

The data telegram contains from each magnet:

- Position (32 bit)
- Long status information (16 bit)

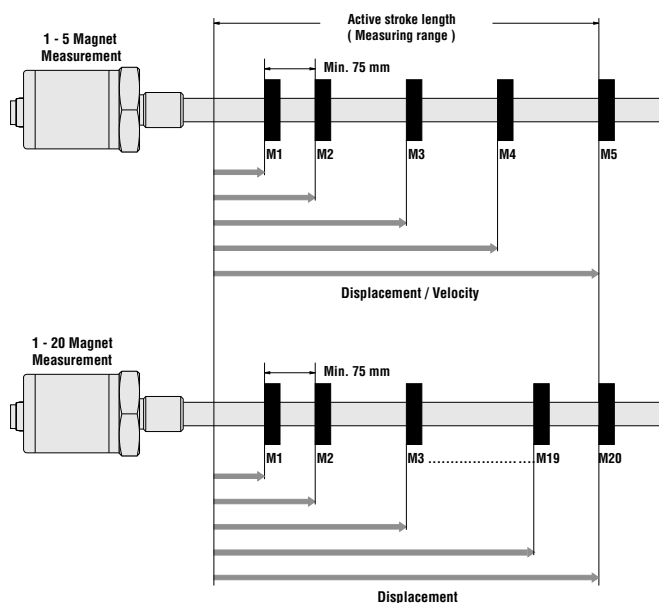

Technical Data

Input	
Measured variable	Displacement / Option: Multi-Magnets measurement (max. 15 positions or 5 positions + 5 velocities)
Measuring length	Profile 25 - 5000 mm / Rod 25 - 7600 mm
Output	
Output signal	EtherCAT Ethernet Control Automation Technology
Data format	EtherCAT
Data transmission rate	100 MBit/s
Accuracy	
Resolution	
- Displacement	adjustable minimum: 1 µm
- Speed	1 µm/s (Quality rating) adjustable according to velocity and measuring length
Linearity	< ± 0,01 % F.S. (Minimum ± 50 µm)
Repeatability	< ± 0,001 % F.S. (Minimum ± 2,5 µm)
Cycle time	Measuring length dependent
Data transmission rate	≤ 10 KHz (Oversampling is active while the scanning cycle is shorter than the measuring cycle.)
Temperature coefficient	<15 ppm/° C
Hysteresis	< 4 µm
Operating conditions	
Magnet speed	any
Operating temperature	-40 °C ... +75 °C
Dew point, humidity	90% rel. humidity, no condensation
Protection	Profile: IP65, Rod: IP67, if mating connector is correctly fitted
Shock test	100 g single hit, IEC-Standard 68-2-27
Vibration test	15g / 10 - 2000 Hz, IEC-Standard 68-2-6
Standards, EMC test	Electromagnetic emission EN 50081-1 Electromagnetic immunity EN 50082-2 EN 61000-4-2/3/4/6, Level 3/4, Criterium A, CE-qualified
Form factor, Material	
Diagnostic display	LEDs beside connector
Profile model:	
Sensor head	Aluminum
Sensor stroke	Aluminum
Position magnet	Magnet slider or removable U-magnet
Rod model:	
Sensor head	Aluminum
Rod with flange	Stainless steel 1.4301 / AISI 304
-Pressure rating	350 bar, 700 bar peak
Position magnet	Ring magnets, U-magnets
Installation	
Mounting position	any orientation
Profile	Movable mounting clamps or T-slot nuts M5 in base channel
U-Magnet, removable	Mounting plate and screws from antimagnetical material
Rod	Threaded flange M18 x 1,5 or 3/4" -16 UNF-3A, Hex nut M18
Position magnet	Mounting plate and screws from antimagnetical material
Electrical connection	
Connection type	2 x 6 pin connector M16 or 2 x 5 pin connector M12 + 4 pin. connector M8
Input voltage	24 VDC (-15 / +20 %)
- Polarity protection	up to -30 VDC
- Overvoltage protection	up to 36 VDC
Current drain	80 mA typical
Ripple	< 1 % S-S
Electric strength	500 V (DC ground to machine ground)

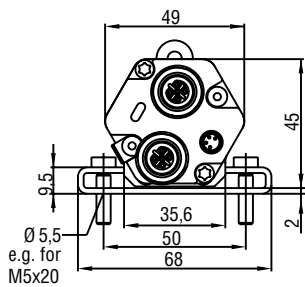

Connector D56

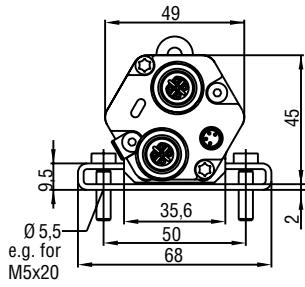

Connector D56

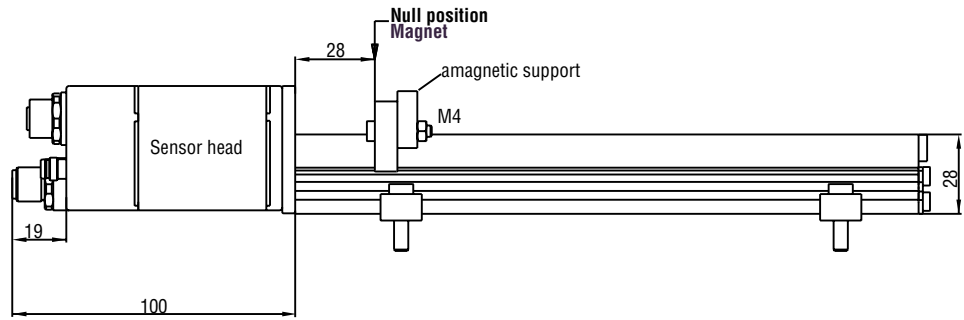
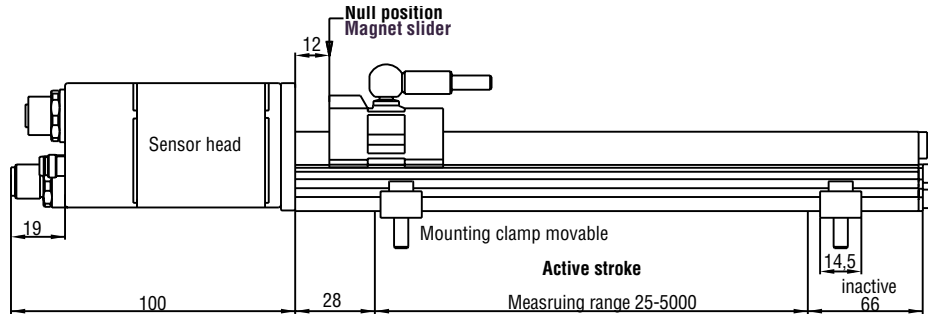

Selection of position magnets (upon delivery)

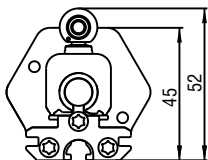

Magnet slider S
Part No. 252 182

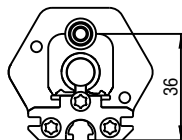

Magnet slider V
Part No. 252 184

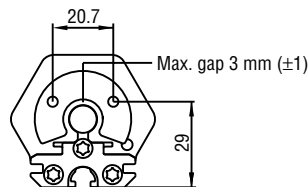

U-Magnet M OD33
Part No. 251 416-2

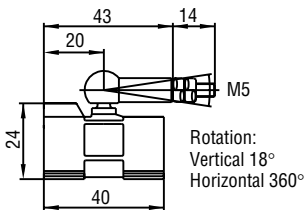

GFK, Magnet Hardferrite
Weigth ca. 30 g
Operating temperature:
-40 ... +75°C

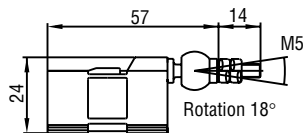

GFK, Magnet Hardferrite
Weigth ca. 30 g
Operating temperature:
-40 ... +75°C

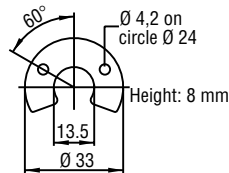

Composite PA-Ferrite-GF20
Weigth ca. 11g
Operating temperature:
-40 ... +100°C

Stable Profile Design

Temposonics-RP offers modular construction, flexible mounting configurations and easy installation. Position measurement is contactless via two versions of permanent magnets.

- A sliding magnet running in profile housing rails. Connection with the mobile machine part is via a ball jointed arm to taking up axial forces.
- A floating magnet, mounted directly on the moving machine part, travels over the profile at a low distance. Its air-gap allows the correction of small misalignments at installation.

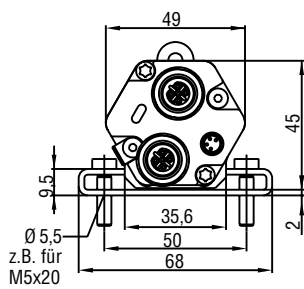

Connector D56

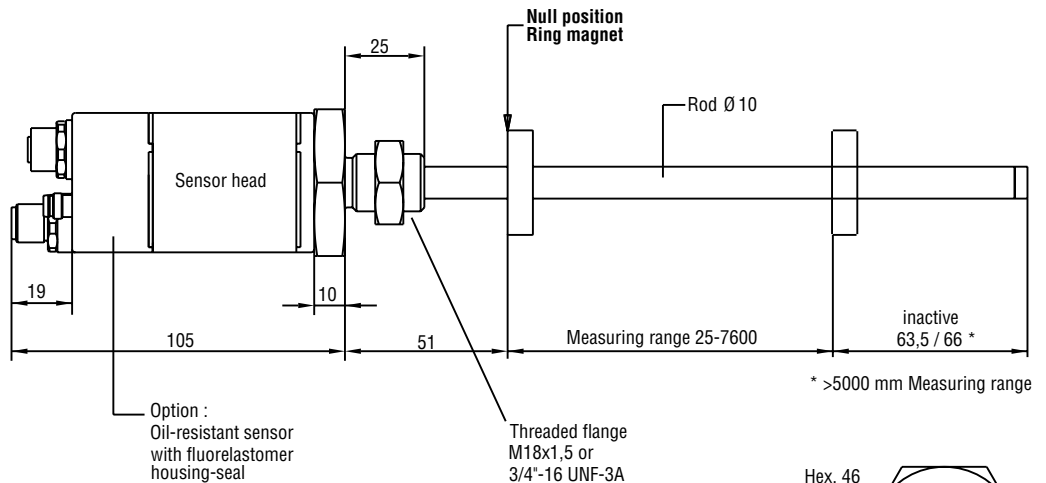

Hex. 46

Ring magnet

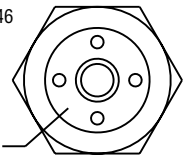

Selection of position magnets (not on delivery)

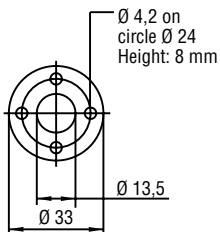

Ring magnet OD33
Part No. 201 542-2

Composite PA-Ferrite-GF20
Weigth ca. 14g
Operating temperature:
-40 ... +100°C

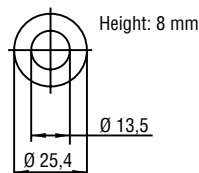

Ring magnet OD25,4
Part No. 400 533

Composite: PA-Ferrite
Weigth ca. 10g
Operating temperature:
-40 ... +100°C

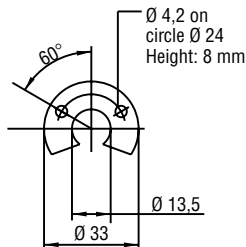

U-magnet M OD33
Part No. 251 416-2

Composite PA-Ferrite-GF20
Weigth ca. 11g
Operating temperature:
-40 ... +100°C

High Pressure Rod Design

Temposonics-RH with a pressure-resistant stainless steel flange and sensing rod is suitable for use in hydraulic cylinders and externally in all applications where space is a problem. Position measurement is via ring or U-magnets travelling along the sensing rod without any mechanical contact.

Advantage...

the completely operable sensor cartridge can be replaced for servicing easily without opening the fluid circuit.

All measurements in mm

Temposonics-RP+RH

EtherCAT

Wiring

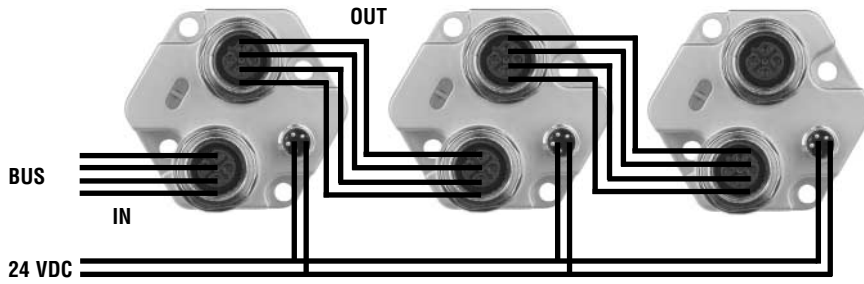

Unused connectors should be covered by a protective cap.

Connection	BUS In / Out	Pin	Cable	Function	Input voltage	Pin	Cable	Supply Voltage
View Connector side Sensor	 female	1	yellow	Tx+	 male	1	brown	+24 VDC (-15/+20%)
		2	white	Rx+		2	white	n.c.
		3	orange	Tx-		3	blue	0 V (GND)
		4	blue	Rx-		4	black	n.c.

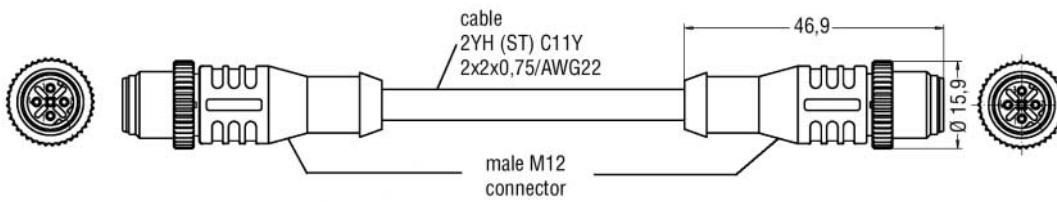

5 m industrial Ethernet cable
(Cat 5e ES)
w/2 4 pin M12-connectors (D-coded)
PUR-jacket, green
Part No. 530 064

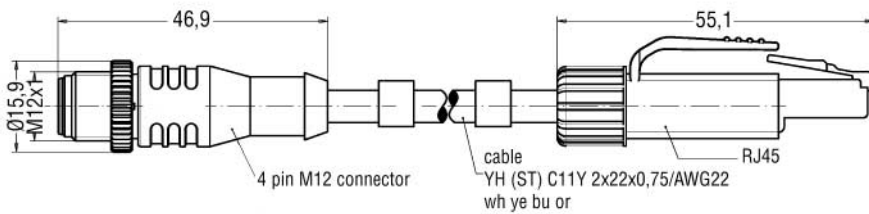

5 m industrial Ethernet cable
(Cat 5e ES)
w/RJ45 connector and
M12-connector (D-coded)
PUR-jacket, green
Part No. 530 065

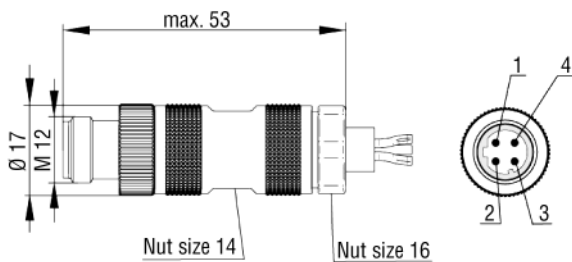

M12 connector (male, D-coded)
w/IDC technology
Part No. 370 523

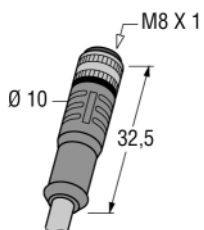

Shielded
PUR-cable w/M8 connector (female)
and pigtail for the 24 VDC input.
Wire gage: 4x0,25 mm²
Part No. 530 066

Flexible installation in any position

Profile model

Normally, the sensor is firmly installed - fixed on a straight surface of the machine with movable mounting clamps or M5 screws in base channel - whilst the magnet is mounted at the mobile machine part.

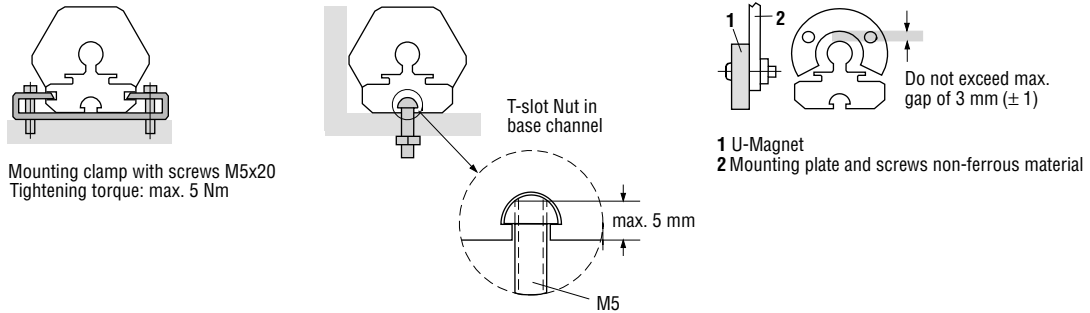

Rod model

Mount the sensor via flange thread or a hex nut. If possible, non-magnetizable material should be used for mounting support (dimensions as shown). With horizontal mounting, longer sensors (from 1 meter) must be provided with mechanical support.

Hydraulic sealing

Recommended is sealing of the flange facing with O-Ring (e.g. 22,4 x 2,65) in a cylinder cover nut or an O-Ring 15,3 x 2,2 in undercut.

Minimum assembly distance

1. Non-magnetizable material

2. Magnetizable material

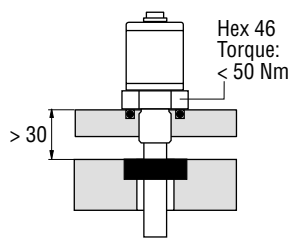

Recommended hydraulic sealing

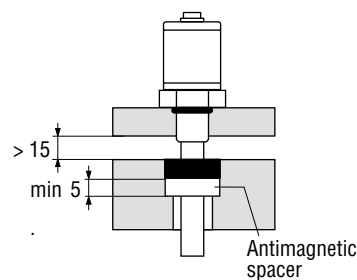

Alternative sealing O-Ring 15,3 x 2,2

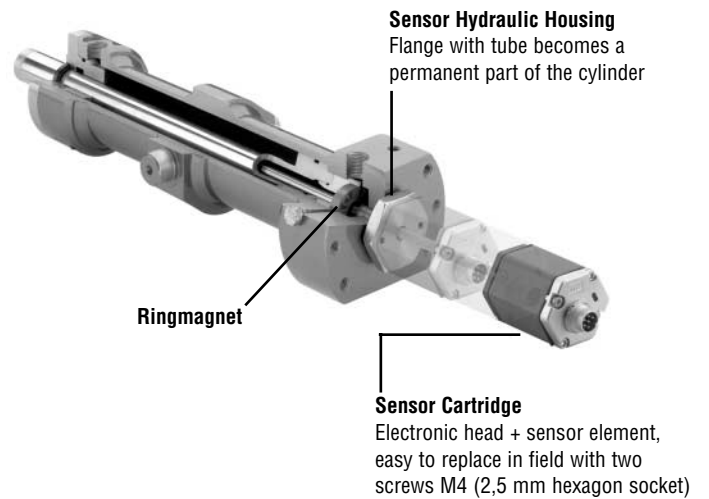

Cylinder installation

When used for direct stroke measurement in fluid cylinders, the sensor's high pressure, stainless steel rod installs into a bore in the piston head/rod assembly as illustrated. That guarantees a longlife and trouble-free operation - independent of used hydraulic fluid.

The sensor cartridge can be removed from the flange and rod housing while still installed in the cylinder. This procedure allows quick and easy sensor cartridge replacement, without the loss of hydraulic pressure.

Temposonics-RP+RH

EtherCAT

Temposonics

Sensor model

RP - Profile

RH - Rod

Form factor

Profile Temposonics-RP:

S - Magnet slider, joint at top

V - Magnet slider, joint at front

M - U-Magnet, OD33

Rod Temposonics-RH:

M - Flange M18 x 1,5 (Standard)

V - Flange M18 x 1,5

(Fluorelastomer housing-seal)

S - Flange 3/4" - 16 UNF - 3A

Measuring length

Profile - 0025...5000 mm

Rod - 0025...7600 mm

Standard: up to 1000 in 50 mm, greater 1000 in 250 mm steps

Other length upon request

Connection type

D56 - 2 x 4 pol. Busgerätedose M12-D, 1 x 4 pol. Stecker M8

Input voltage

1 - +24 VDC

Output

E 101 - EtherCAT, 1-5 Magnet measurement

E 102 - EtherCAT, 1-20 Magnet measurement

On delivery Profile Model:

Sensor, magnet slider or U-magnet, 2 mounting clamps up to 1250 mm stroke + 1 clamp for every additional 500 mm
Installation guide + CD-ROM (XML-File).

On delivery Rod Model:

Sensor and hex nut.
Installation guide + CD-ROM (XML-File).

Magnets must be ordered separately.

Note: Projecting and parameterizing a EtherCAT system will be done with servicetool of EtherCAT mastersystem supplier.

Accessories (selection)

Magnet slider type »S«

Magnet slider type »V«

U-Magnet OD33, corresponding type »M«

Ring magnet OD33, Standard

Ring magnet OD25,4

O-Ring 15,3 x 2,2 Fluorelastomer FPM 75

Mounting clamp

T-slot nut M5 for base channel mounting

Part No.

252 182

252 184

251 416-2

201 542-2

400 533

401 133

400 802

401 602

Accessories (selection)

Bus cable 5 m, 2 x M12-D connector

Bus cable 5 m m12-D connector, RJ45 connector

4 pin Bus cable connector M12-D, selbstkonfektionierbar

PUR cable 5 m, M8 female connector, open end (24V)

Part No.

530 064

530 065

370 523

530 066

www.mtssensor.de
www.temposonics-shop.de
Service Hotline: 01805 - mtssensor

© MTS Temposonics® R-Series Temposonics RPRH EtherCAT 05092006e - Alterations reserved

MTS
SENSORS

Germany

MTS Sensor Technologie
GmbH & Co. KG
Auf dem Schüffel 9
D-58513 Lüdenscheid
Tel.: +49-2351-9587-0
Fax: +49-2351-56491
info@mtssensor.de
www.mtssensor.de

USA

MTS Systems Corporation
Sensors Division
3001 Sheldon Drive
Cary, NC 27513, USA
Tel.: +1-919-677-0100
Fax: +1-919-677-0200
info@mtssensors.com
www.mtssensors.com

Japan

MTS Sensors Technology Corp.
Ushikubo Bldg.
737 Aihara-cho, Machida-shi
Tokyo 194-0211, USA
Tel.: +81-42-775-3838
Fax: +81-42-775-5516
info@mtssensor.co.jp
www.mtssensor.co.jp