

## R-Series CANopen ● CANbasic

**Temposonics RP and RH**  
Measuring length 25 - 7600 mm



More than just a sensor  
**Multi-Position Measurement**

**New: Diagnostic LED**



- Rugged Industrial Sensor
- Linear and Absolute Measurement
- LEDs for Sensor Diagnostic
- Contactless Sensing with Highest Durability
- Superior Accuracy: Resolution up to 2 µm
- Linearity better 0,01 %
- Repeatability 0,001 %
- Sensor-based intelligence
- Direct CAN Output, Displacement + Speed
- Multi-Position Measurement (1 Sensor for 15 Positions)

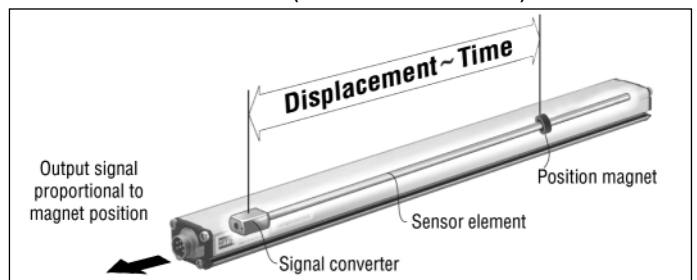

**Magnetostriction**

**Form factor**

The absolute **Temposonics®** linear position sensors are based on the MTS developed magnetostrictive measurement principle. That combines various magneto-mechanical effects and uses the physical high precise speed-measurement of an ultrasonic wave (torsion pulse in its sensor element) for position detecting. Sensor integrated signal processing transforms the measurements directly into market standard outputs. The contactless principle - an external movable magnet marks the position - eliminates the wear, noise and erroneous signal problems and guarantees the best durability without any recalibration.

The extremely robust sensor, ideal for continuous operation under harshest industrial conditions is completely modular in mechanic and electronic design.

- A profile or rod-shaped sensor housing protects the sensing element in which gives rise to the measurement signal.
- The sensor head accommodates the complete modular electronic interface with active signal conditioning. Double encapsulation ensures high operating safety and optimum EMC protection.
- The position transmitter, a permanent magnet - fixed at the mobile machine part - drives contactlessly over the sensor's stroke and starts measuring through the housing wall.

## New...a sensor diagnostic display

Integrated LEDs (green/red) provide basic visual feedback for normal sensor operation and troubleshooting.

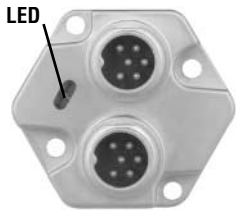

Green	Red	Description
ON	OFF	Normal function
ON	ON	Magnet not detected or wrong quantity of magnets
OFF	ON	Initialization error
Flashing	Flashing	Power out of range (high or low)

## CAN Bus Interface

Temposonics position sensors fulfill - as slave devices - all requirements of the CAN-Bus (ISO 11898). The sensors electronics convert the displacement measurements into bus oriented outputs and transfer these data directly to the control unit. The bus interface is appropriate for serial data transfer of 1 Mbit/s maximum. Sensor integrated software supports the Bus profiles **CANopen**, **CANbasic** and **DeviceNet** for a comprehensive customized configuration of the sensor-bus system.

### Operation modes

CAN sensors provide following measurements with **one** or **multiple** magnets:

#### 1. Standard measurement:

- **CANbasic**: Displacement + speed with 1 magnet
- **CANopen**: Displacement + speed with 1 - 4 magnets

#### 2. Multi-Magnets measurement:

- **CANbasic**: Positions for each of 2-15 magnets *simultaneously*

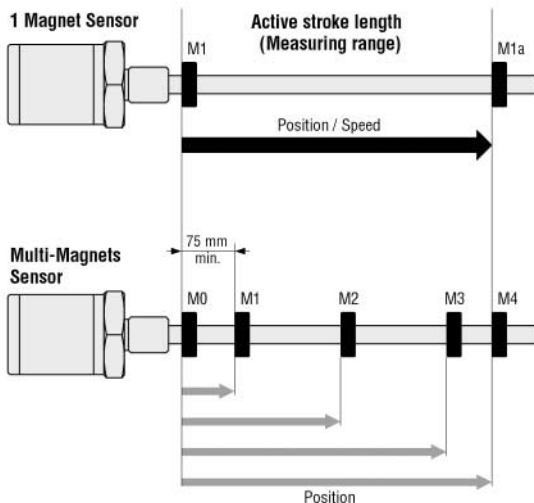

## TEMPOSONICS CANbus Variations

### 1. CANopen

is corresponding to encoder profile DS-406 V3.1 (CiA Standard DS-301 V4.02). CANopen functionality describes communication objects (below), which are set via configuration tool.

- **Service Data Object (SDO)** main usage is the sensor configuration. Selectable parameters: Resolution for position + speed, 4 set-points, Preset of operation range and null position for 4 magnets.
- **Process Data Object (PDO)** is used for real-time data transfer of sensor measurements in max. 8 bytes data blocks. The sensor uses PDOs for information about position, speed, limit status, cam-control and operation range of 4 magnets. Data formats: Positions = 32-bit and speed = 16-bit integer value. Limit value = 8-bit.
- **PDO Transmission Type**: Asynchronous (cycle time of 1 to 65'535 ms) or synchronous.
- **Synchronisation Object (SYNC)**
- **Emergency Object**
- **Nodeguard Object**
- **CANopen Configuration Tool** is a software (CD-Rom) and is used as an Electronic Data Sheet (EDS) for sensor configuration. Each sensor will be delivered with an operating manual and an EDS.

### 2. CANbasic (MTS)

permits a simple, flexible adaption to customized profiles with a short bus access. Here, no configuration tool is needed because parameters are factory set. CANbasic protocol complies with CAN 2.0A standard and always includes the following applications data for 1-Magnet measurement: Position, Speed, Sensor Status and 5 Setpoints.

### 3. CANbasic Multi-Magnets Measurement

provides the position measurement with **maximum 15 magnets on one sensor**. Set-ups and operation are via the on-site control system according to MTS instruction manual.

Data protocols of above CAN options are factory set in the sensor processor, so all versions can be connected directly to the fieldbus.

Conformance Test Certificate No. CiA199902-301V30/I-004 is given by the CANbus user organisation CiA (CAN in Automation) for MTS CANopen sensors.

### Accessory: MTS Servicetool

**CANopen Address Programmer** is used for setup the Node-Address to sensors with CANopen interface. This setup normally is done by the **LMT/LSS-Service** of the bus. Since some master systems do not support this standard, or customer controller system can not handle, this tool - connected to the sensor - can be used for direct setup.

## Technical Data

### Input

Measured variables	Displacement, speed / Option: Multi-Magnets measurement (max. 15 positions simultaneous)
Measuring range	Profile 25 - 5000 mm / Rod 25 - 7600 mm

### Output

Interface	CAN-Fieldbus System ISO-DIS 11898						
Data protocol	<b>CANopen:</b> CIA Standard DS 301 V3.0 / Encoder Profile DS 406 V3.1, <b>CANbasic:</b> CAN 2.0 A						
Baud rate, kBit/s	1000	800	500	250	125	50	20
Cable length, m	< 25	< 50	< 100	< 250	< 500	< 1000	< 250
Overvoltage protection	The sensor will be supplied with ordered baud rate, which is changeable by customer up to 36 VDC						

### Accuracy

Resolution	CANopen		CANbasic	
- Displacement	5 µm	2 µm	5 µm	2 µm
- Speed	0,5 mm/s	0,2 mm/s	1,0 mm/s	0,1 mm/s
Update time	1,0 ms up to 2400 / 2,0 ms up to 4800 / 4,0 ms up to 7600 mm stroke length			
Linearity	0,5 ms bis 1200 mm zusätzlich für CANbasic			
Repeatability	< ± 0,01 % F.S. (Minimum ± 40 µm), independent of outside temperatures			
Temperature coefficient	< ± 0,001 % F.S. (Minimum ± 2,5 µm)			
Hysteresis	< 15 ppm/°C			
	< 4 µm			

### Operating conditions

Magnet speed	Any
Operating temperature	-40 °C ... +75 °C
Dew point, humidity	90% rel. humidity, no condensation
Protection	Profile style: IP65 / Rod style: IP67, IP68 for cable outlet
Shock test	100 g, single hit, IEC-Standard 68-2-27
Vibration test	15g / 10 - 2000 Hz, IEC-Standard 68-2-6
Standards, EMC test	Electromagnetic emission EN 50081-1 Electromagnetic immunity EN 50082-2 EN 61000-4-2/3/4/6, Level 3/4, Criterium A, CE-qualified

### Form factor, material

Diagnostic display	LEDs beside connector
Profile model:	
Sensor head	Aluminum
Sensor stroke	Aluminum
Position magnet	Magnet slider or removable U-magnet
Rod model:	
Sensor head	Aluminum
Rod with flange	Stainless steel 1.4301 / AISI 304
-Pressure rating	350 bar, 700 bar peak
Position magnet	Ring magnets, U-magnets

### Installation

Mounting position	Any orientation
Profile	Movable mounting clamps or T-slot nuts M5 in base channel
U-Magnet, removable	Mounting plate and screws from antimagnetical material
Rod	Threaded flange M18 x 1,5 or 3/4" -16 UNF-3A, Hex nut M18
Position magnet	Mounting plate and screws from antimagnetical material

### Electrical connection

Connection type	Single or dual 6 pin connectors M16 or cable outlet
Input voltage	24 VDC (-15 / +20 %)
- Polarity protection	up to -30 VDC
- Overvoltage protection	up to 36 VDC
Current drain	90 mA typical
Ripple	< 1 % S-S
Electric strength	500 V (DC ground to machine ground)

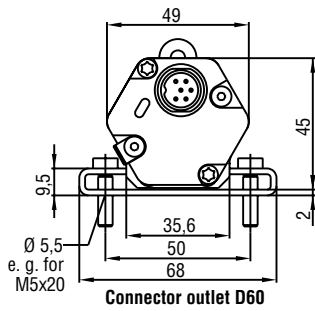

Connector outlet D60

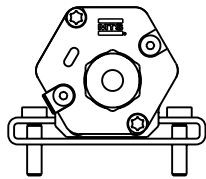

Cable outlet DP02

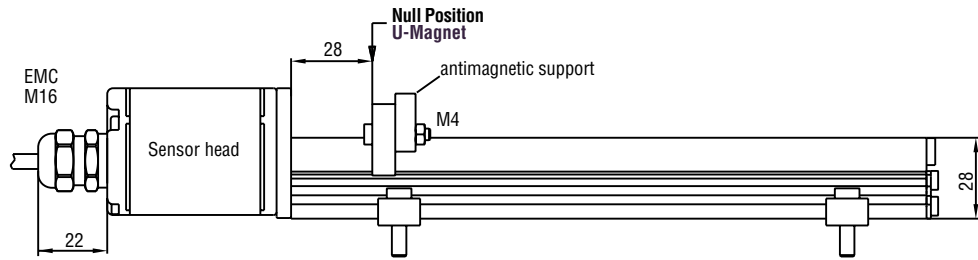
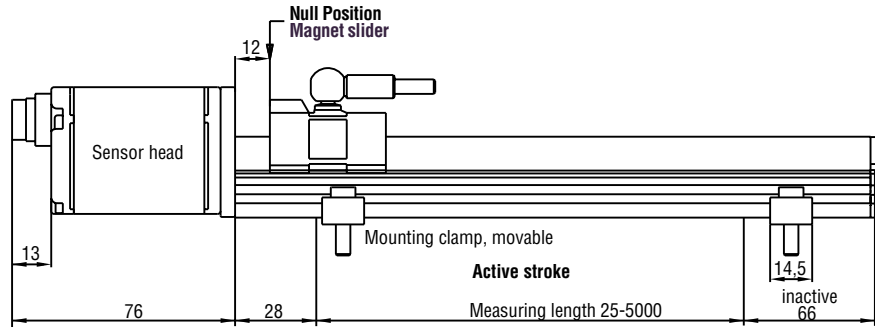

**Selection of position magnets (upon delivery)**

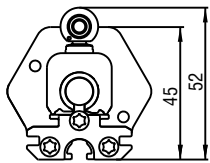

**Magnet slider S**  
Part No. 252 182

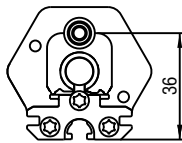

**Magnet slider V**  
Part No. 252 184

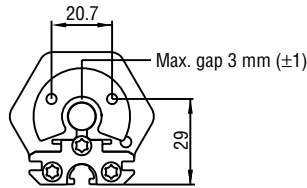

**U-Magnet M OD33**  
Part No. 251 416-2

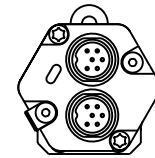

Connector outlet D62

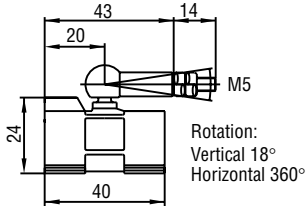

GFK, Magnet Hardferrite  
Weigth ca. 30 g  
Operating temperature:  
-40 ... +75°C

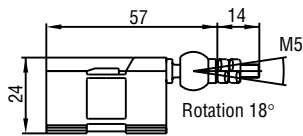

GFK, Magnet Hardferrite  
Weigth ca. 30 g  
Operating temperature:  
-40 ... +75°C

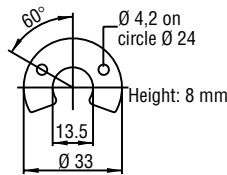

Composite PA-Ferrite-GF20  
Weigth ca. 11g  
Operating temperature:  
-40 ... +100°C

**Stable Profile Design**

Temposonics-RP offers modular construction, flexible mounting configurations and easy installation. Position measurement is contactless via two versions of permanent magnets.

- A sliding magnet running in profile housing rails. Connection with the mobile machine part is via a ball jointed arm to taking up axial forces.
- A floating magnet, mounted directly on the moving machine part, travels over the profile at a low distance. Its air-gap allows the correction of small misalignments at installation.

**Connection types**

**1. Connector outlet D60**  
6 pin male receptacle M16

**2. Connector outlet D62**  
2 x 6 pin male receptacle M16

**3. Cable outlet P02**  
2 m PUR cable 7 x 0,14 mm<sup>2</sup>  
Cable Ø 6,8 mm  
EMC shielded, 50 mm bending radius at fixed installation

All measurements in mm

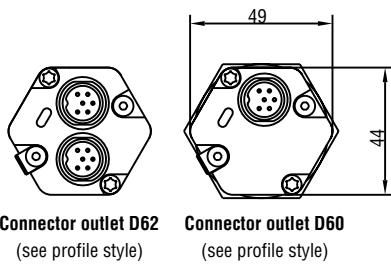

**Connector outlet D62**  
(see profile style)

**Connector outlet D60**  
(see profile style)

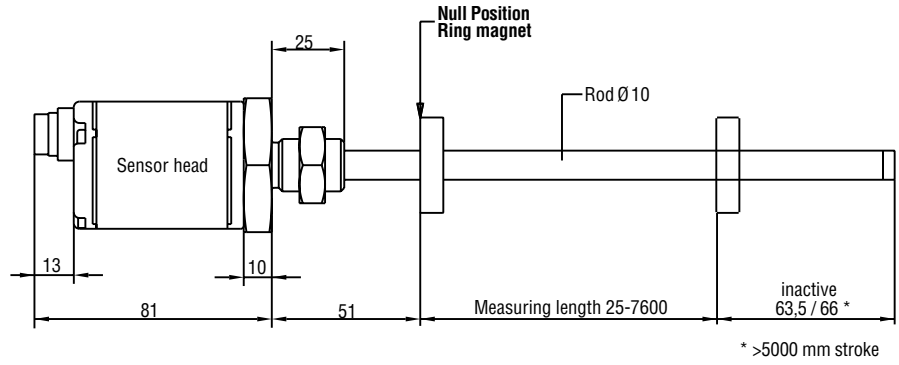

\* >5000 mm stroke

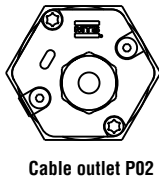

**Cable outlet P02**

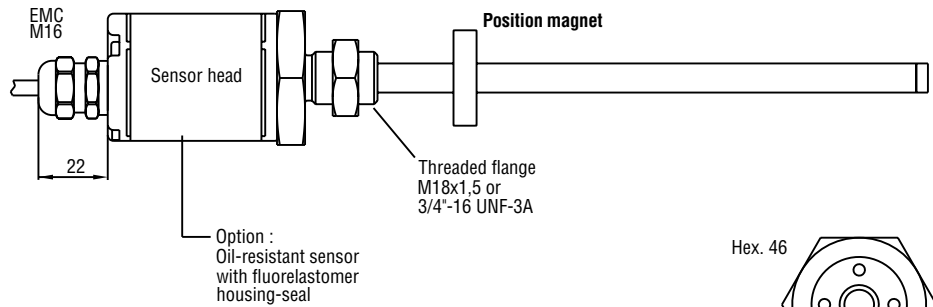

Option :  
Oil-resistant sensor  
with fluorelastomer  
housing-seal

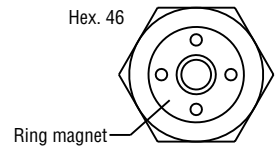

Hex. 46  
Ring magnet

**Selection of position magnets (not on delivery)**

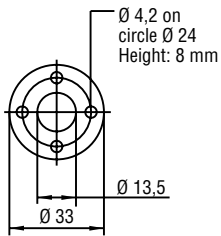

**Ring magnet OD33**  
Part No. 201 542-2

Composite PA-Ferrite-GF20  
Weigh ca. 14g  
Operating temperature:  
-40 ... +100°C

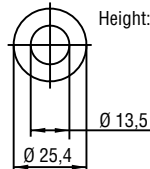

**Ring magnet OD25,4**  
Part No. 400 533

Composite: PA-Ferrite  
Weigh ca. 10g  
Operating temperature:  
-40 ... +100°C

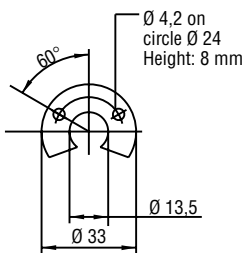

**U-magnet M OD33**  
Part No. 251 416-2

Composite PA-Ferrite-GF20  
Weigh ca. 11g  
Operating temperature:  
-40 ... +100°C

**High Pressure Rod Design**

Temposonics-RH with a pressure-resistant stainless steel flange and sensing rod is suitable for use in hydraulic cylinders and externally in all applications where space is a problem. Position measurement is via ring or U-magnets travelling along the sensing rod without any mechanical contact.

**Advantage...**

the completely operable sensor cartridge can be replaced for servicing easily without opening the fluid circuit.

## Flexible installation in any position

### Profile model

Normally, the sensor is firmly installed - fixed on a straight surface of the machine with movable mounting clamps or M5 screws in base channel - whilst the magnet is mounted at the mobile machine part.

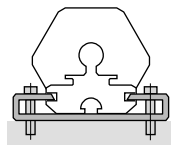

Mounting clamp with screws M5x20  
Tightening torque: max. 5 Nm

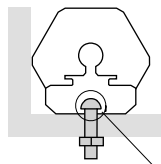

T-slot Nut in base channel

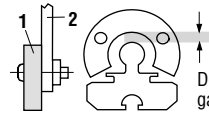
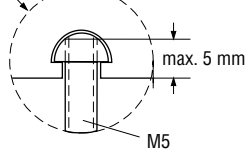

Do not exceed max. gap of 3 mm ( $\pm 1$ )

- 1 U-Magnet
- 2 Mounting plate and screws non-ferrous material

### Rod model

Mount the sensor via flange thread or a hex nut. If possible, non-magnetizable material should be used for mounting support (dimensions as shown). With horizontal mounting, longer sensors (from 1 meter) must be provided with mechanical support.

### Hydraulic sealing

Recommended is sealing of the flange facing with O-Ring (e.g. 22,4 x 2,65) in a cylinder cover nut or an O-Ring 15,3 x 2,2 in undercut.

### Minimum assembly distance

1. Non-magnetizable material

2. Magnetizable material

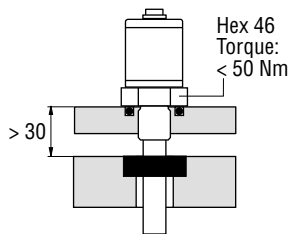

Recommended hydraulic sealing

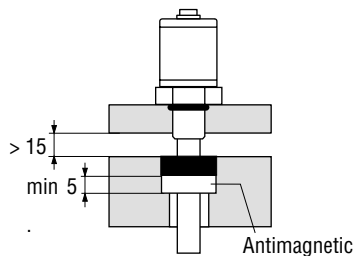

Alternative sealing  
O-Ring 15,3 x 2,2

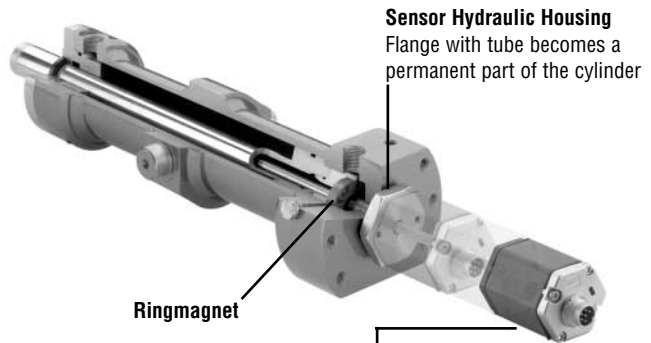

### Sensor Hydraulic Housing

Flange with tube becomes a permanent part of the cylinder

Ringmagnet

### Sensor Cartridge

Electronic head + sensor element, easy to replace in field with two screws M4 (2,5 mm hexagon socket)

### Cylinder installation

When used for direct stroke measurement in fluid cylinders, the sensor's high pressure, stainless steel rod installs into a bore in the piston head/rod assembly as illustrated. That guarantees a longlife and trouble-free operation - independent of used hydraulic fluid.

The sensor cartridge can be removed from the flange and rod housing while still installed in the cylinder. This procedure allows quick and easy sensor cartridge replacement, without the loss of hydraulic pressure.

### Wiring

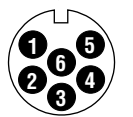

Male insert sensor plug rear of cable connector

Pin	Cable	Function
1	grey	CAN (-)
2	pink	CAN (+)
3	n.c.	--
4	n.c.	--
5	brown	$\pm 24$ VDC ( -15/+20 %)
6	white	0 V

### Cable connector (recommended, not on delivery)

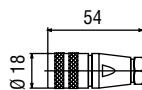

6 pin female connector M16, PG9  
Part No. ST C0 9131 D06 PG9

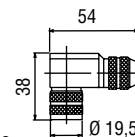

6 pin 90° female connector M16  
insert adjustable in 45° positions  
Part No. ST C0 9131-6

Housing: Zinc nickel plated  
Termination: Solder  
Contact insert: Silver plated  
Cable clamp: PG7  
Max. Cable-Ø 6mm  
Cable clamp: PG9, M16  
Max. Cable-Ø 8 mm (PG9, M16)

**Temposonics**

**Sensor model**

RP - Profile  
RH - Rod

**Form factor**

**Profile Temposonics-RP:**

S - Magnet slider, joint to top  
V - Magnet slider, joint at front  
M - U-Magnet, OD33

**Rod Temposonics-RH:**

M - Flange M18 x 1,5 (Standard)  
V - Flange M18 x 1,5  
(Fluorelastomer housing-seal)  
S - Flange 3/4" - 16 UNF - 3A

**Measuring length**

Profile - 0025...5000 mm  
Rod - 0025...7600 mm  
Standard: up to 1000 in 50 mm, greater 1000 in 250 mm steps  
Other length upon request

**Connection type**

D60 - 6 pin male receptacle M16  
D62 - 2 x 6 pin male receptacle M16  
P02 - 2 m PUR cable w/o connector, Option: P01-P10 (1-10 m)

**Input voltage**

1 - +24 VDC

**Output**

C [1][2][3][4][5][6] = CAN-Bus

[1][2][3] Protocol:           **101** = CANbasic (MTS) • **207** = Multi-Position measurement • **304** = CANopen  
[4] Baud rate:               **1** = 1000 kBit/s • **2** = 500 kBit/s • **3** = 250 kBit/s • **4** = 125 kBit/s  
[5] Resolution:              **1** = 5 µm • **2** = 2 µm  
[6] Type:                      **1** = Standard

**Magnet number for Multi-Position measurement\***

Z02 - Z15 = 2 - 15 pcs.

\*Note: Pls. specify magnet numbers for your sensing application and order separately

**On delivery Profile model:** Sensor, Position magnet, 2 mounting clamps up to 1250 mm + 1 clamp for every additional 500 mm.

**On delivery Rod model:** Sensor, hex nut, pls. order magnet (see below) separately.

**CANopen only:** Installation guide + CD-ROM (Electronic Data Sheet)

**Accessories (selection)**

	<b>Part No.</b>
Magnet slider type »S«	252 182
Magnet slider type »V«	252 184
U-Magnet OD33, corresponding type »M«	251 416-2
Ring magnet OD33, Standard	201 542-2
Ring magnet OD25,4	400 533
O-Ring 15,3 x 2,2 Fluorelastomer FPM 75	401 133
Mounting clamp	400 802
T-slot nut M5 for base channel mounting	401 602
6 pin female cable connector M16, PG9	STC 09131 D06 PG9
6 pin 90°-female cable connector M16,	STC 09131-6
PUR-cable 7 x 0,14 mm <sup>2</sup>	K26
<b>MTS-Service tools</b>	
CANopen Adress Programmer	252 382-D62

[www.mtssensor.de](http://www.mtssensor.de)  
[www.temposonics-shop.de](http://www.temposonics-shop.de)  
**Service Hotline: 01805 - mtssensor**

© MTS Temposonics® R-Series Temposonics RPRH CANbus 24032006e - Alterations reserved

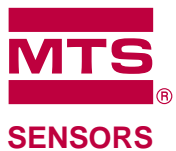

**Germany**  
MTS Sensor Technologie  
GmbH & Co. KG  
Auf dem Schüffel 9  
D-58513 Lüdenscheid  
Tel.: +49-2351-9587-0  
Fax: +49-2351-56491  
[info@mtssensor.de](mailto:info@mtssensor.de)  
[www.mtssensor.de](http://www.mtssensor.de)

**USA**  
MTS Systems Corporation  
Sensors Division  
3001 Sheldon Drive  
Cary, NC 27513, USA  
Tel.: +1-919-677-0100  
Fax: +1-919-677-0200  
[info@mtssensors.com](mailto:info@mtssensors.com)  
[www.mtssensors.com](http://www.mtssensors.com)

**Japan**  
MTS Sensors Technology Corp.  
Ushikubo Bldg.  
737 Aihara-cho, Machida-shi  
Tokyo 194-0211, Japan  
Tel.: +81-42-775-3838  
Fax: +81-42-775-5516  
[info@mtssensor.co.jp](mailto:info@mtssensor.co.jp)  
[www.mtssensor.co.jp](http://www.mtssensor.co.jp)