

R-Series Analog

Temposonics RP and RH
Measuring length 50 - 7600 mm



100% field adjustable Null and Span

New: Diagnostic LED



- Rugged Industrial Sensor
- Linear and Absolute Measurement
- LEDs for Sensor Diagnostics
- Contactless Sensing with Highest Durability
- Superior Accuracy: Linearity better 0,01 %
- Repeatability 0,001 %
- Direct Analog Output, Displacement + Speed
- Dual Magnet Position Measurement

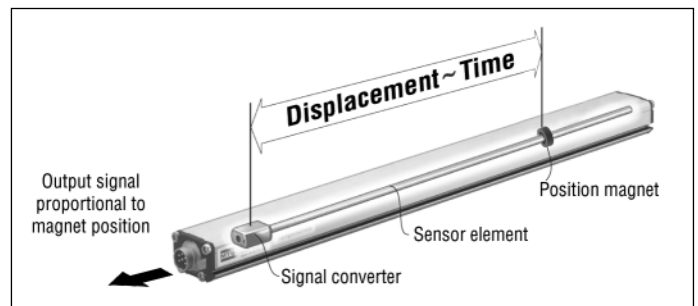

Magnetostriction

The absolute **Temposonics®** linear position sensors are based on the MTS developed magnetostrictive measurement principle. That combines various magneto-mechanical effects and uses the physical high precise speed-measurement of an ultrasonic wave (torsion pulse in its sensor element) for position detecting. Sensor integrated signal processing transforms the measurements directly into market standard outputs. The contactless principle - an external movable magnet marks the position - eliminates the wear, noise and erroneous signal problems and guarantees the best durability without any recalibration.

Form factor

The extremely robust sensor, ideal for continuous operation under harshest industrial conditions is completely modular in mechanic and electronic design.

- A profile or rod-shaped sensor housing protects the sensing element in which gives rise to the measurement signal.
- The sensor head accommodates the complete modular electronic interface with active signal conditioning. Double encapsulation ensures high operating safety and optimum EMC protection.
- The position transmitter, a permanent magnet - fixed at the mobile machine part - drives contactlessly over the sensor's stroke and starts measuring through the housing wall.

Temposonics-RP+RH

Analog

New...a sensor diagnostic display

Integrated LEDs (green/red) provide basic visual feedback for normal sensor operation and troubleshooting.



Green	Red	Description
ON	OFF	Normal function
ON	ON	Magnet not detected, Wrong quantity of magnets
ON	Flashing	Magnet out of setup range
Flashing	ON	Programming mode

Output

Smart analog sensors provide direct analog outputs including voltage and current. All outputs allow 100 % adjustments of zero and span setpoints. Since the outputs are direct, no signal conditioning electronics are needed when interfacing with controllers or meters.

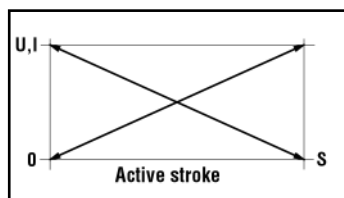

Availability

- Single Magnet Sensor provides one displacement output over the entire active stroke length and one velocity output with 1 magnet.
- Dual Magnets Sensor provides two identical displacement outputs; a separate output is provided for each of two magnets positioned along sensor length.

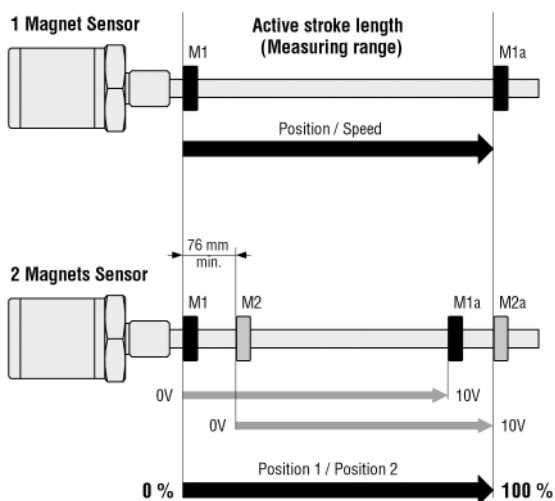

Sensor field programming

Temposonics R-Series sensors are preconfigured at the factory by model code designation. If needed, MTS offers different external service tools for modifying sensor parameters inside the **active electrical stroke** (minimum 25 mm between setpoints) via the standard connection cable. There is no need to open the sensors electronics. Following tools are available:

1. Hand-Programmer R-Analog for 1 Magnet Sensor

for easy teach-in setups of measuring length and direction by moving the magnet on desired Null/Span positions and pushing the 0/100 % buttons.



Hand-Programmer R-Analog, Part No. 253 124

2. Cabinet-Programmer R-Analog

Cabinet-Programmer R-Analog completes the accessories program of MTS absolute position sensors. The unit can be used for adjusting a connected 1-magnet sensor via the leads, using a simple teach-in procedure in the field.

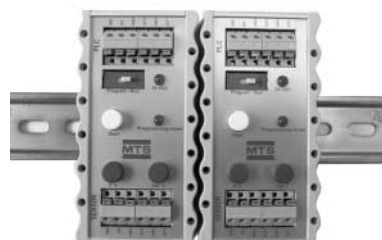

Cabinet-Programmer R-Analog, Part Nr. 253 408

10 x 55 x 31 mm

3. PC-Programmer R-Analog for 1 or 2 Magnets Sensors

This hardware converter is required to communicate via serial port of a Windows PC to the sensor. Customized settings are possible by using the MTS programming software (CD-ROM) for:

- Zero/Span Magnet 1
- Zero/Span Magnet 2
- Velocity range
- Free assignment of outputs to measured position or velocity
- Error output value (e.g. magnet out of stroke)

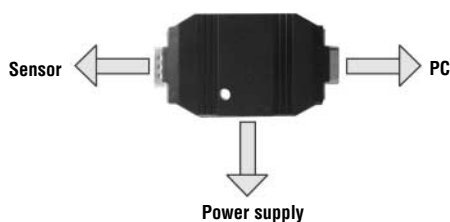

Programming Kit, Part No. 253 134

(PC-Programmer, Power supply, Cable, Software)

Windows sensor programming

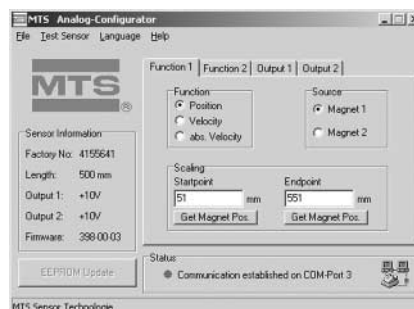

Technical Data

Input	
Measured variables	Position, Speed / Dual magnets position measurements
Measuring range	Profile: 50 - 5000 mm, Rod: 50 - 7600 mm
Output	
Voltage	0...10 / 10...0 / -10...+10 / +10...-10 VDC (min. load controller: > 5 kOhms)
Current	4(0)...20 mA / 20...4(0) mA (min/max. load: 0/500 Ohms)
Overvoltage protection	up to 36 VDC
Accuracy	
Position measurement:	
- Null/Span adjustment	100 % of electrical stroke (Min. range 25 mm)
- Resolution	16 bit; 0,0015 % (Minimum 1 µm)
- Linearity	< ± 0,01 % F.S. (Minimum ± 50 µm)
- Repeatability	< ± 0,001 % F.S. (Minimum ± 1 µm)
- Hysteresis	< 4 µm
- Update time	0,5 ms up to 1200 mm / 1,0 ms up to 2400 mm / 2,0 ms up to 4800 mm / 5,0 ms up to 7600 mm stroke length
- Ripple	< 0,01 % F.S.
Speed measurement:	
- Range	0,025 - 10 m/s
- Deviation	< 0,5 %
- Resolution	0,1 mm/s Option 0,01 mm/s
- Update time (ms)	see position measurement
Temperature coefficient	< 30 ppm/°C
Operating conditions	
Magnet speed	any
Operating temperature	-40 °C ... +75 °C
Dew point, humidity	90% rel. humidity, no condensation
Protection	Profile: IP 65, Rod: IP 67, IP 68 for cable outlet
Shock test	100 g single hit, IEC-Standard 68-2-27
Vibration test	15g / 10 - 2000 Hz, IEC-Standard 68-2-6
Standards, EMC test	Electromagnetic emission EN 50081-1 Electromagnetic immunity EN 50082-2 EN 61000-4-2/3/4/6, Level 3/4, Criterium A, CE-qualified
Form factor, material	
Diagnostic display	LEDs beside connector
Profile model:	
Sensor head	Aluminum
Sensor stroke	Aluminum
Position magnet	Magnet slider or removable U-magnet
Rod model:	
Sensor head	Aluminum
Rod with flange	Stainless steel 1.4301 / AISI 304
-Pressure rating	350 bar, 700 bar peak
Position magnet	Ring magnets, U-magnets
Installation	
Mounting position	any orientation
Profile	Movable mounting clamps fixed with M5 x 20 screws or T-slot nuts M5 in base channel
U-Magnet, removable	Mounting plate and screws from antimagnetical material
Rod	Threaded flange M18 x 1,5 or 3/4" -16 UNF-3A, Hex nut M18
Position magnet	Mounting plate and screws from antimagnetical material
Electrical connection	
Connection type	6 pin connector M16 or 2 m cable
Input voltage	24 VDC (-15 / +20 %)
- Polarity protection	up to -30 VDC
- Overvoltage protection	up to 36 VDC
Current drain	100 mA typical
Ripple	< 1 % S-S
Electric strength	500 V (DC ground to machine ground)

Linearity protocol

Temposonics-RP, stroke 2500 mm
Tolerance allowed: ± 0,25 mm
Tolerance measured: typical ± 0,116 mm
uncorrected

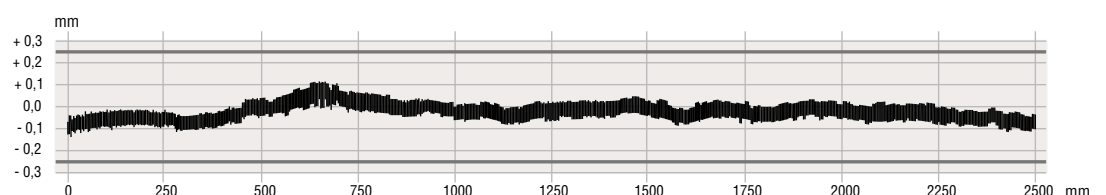

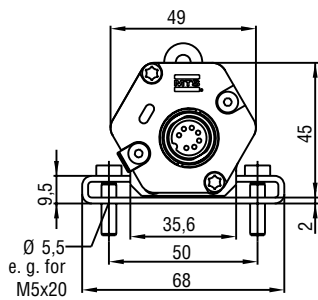

Connector outlet D60

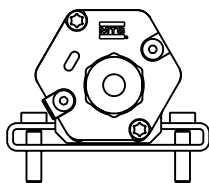

Cable outlet R02
Cable outlet H02

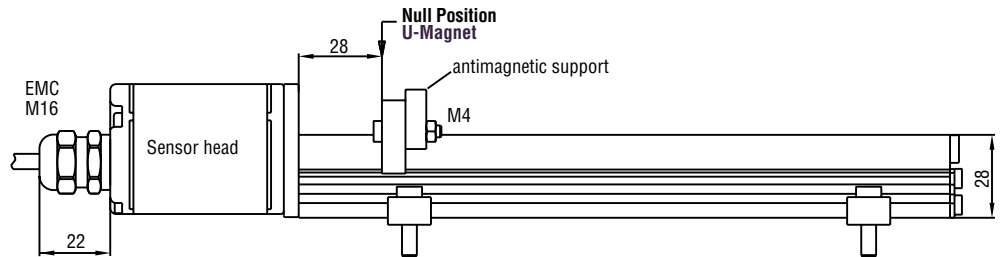
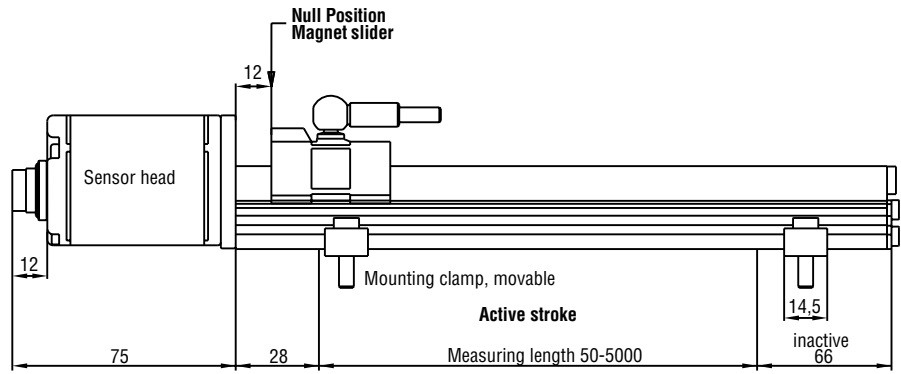

Selection of position magnet (upon delivery)

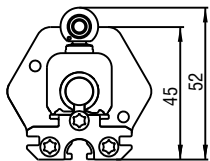

Magnet slider S
Part No. 252 182

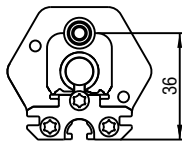

Magnet slider V
Part No. 252 184

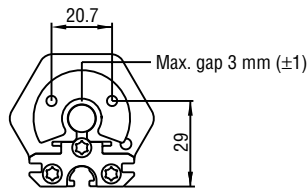

U-Magnet M OD33
Part No. 251 416-2

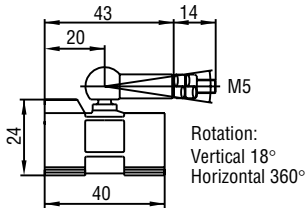

GFK, Magnet Hardferrite
Weigth ca. 30 g
Operating temperature:
-40 ... +75°C

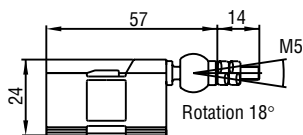

GFK, Magnet Hardferrite
Weigth ca. 30 g
Operating temperature:
-40 ... +75°C

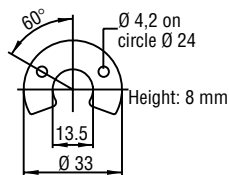

Composite PA-Ferrite-GF20
Weigth ca. 11g
Operating temperature:
-40 ... +100°C

Stable Profile Design

Temposonics-RP offers modular construction, flexible mounting configurations and easy installation. Position measurement is contactless via two versions of permanent magnets.

- A sliding magnet running in profile housing rails. Connection with the mobile machine part is via a ball jointed arm to taking up axial forces.
- A floating magnet, mounted directly on the moving machine part, travels over the profile at a low distance. Its air-gap allows the correction of small misalignments at installation.

Connection types

1. Connector outlet D60
6 pin Male receptacle M16

2. Cable outlet R02
2 m PVC cable 3 x 2 x 0,14 mm²
Outer cable dia. 6 mm

3. Cable outlet H02
2 m PUR cable 3 x 2 x 0,25 mm²
Cable Ø 6,8 mm

*Screened unshielded twisted pair
50 mm bending radius at fixed
installation*

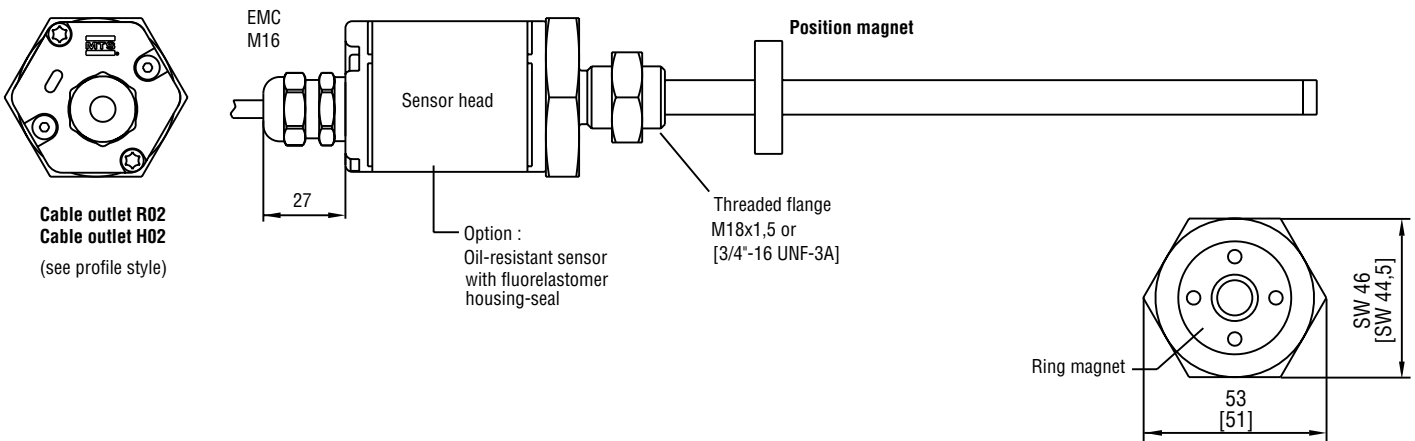
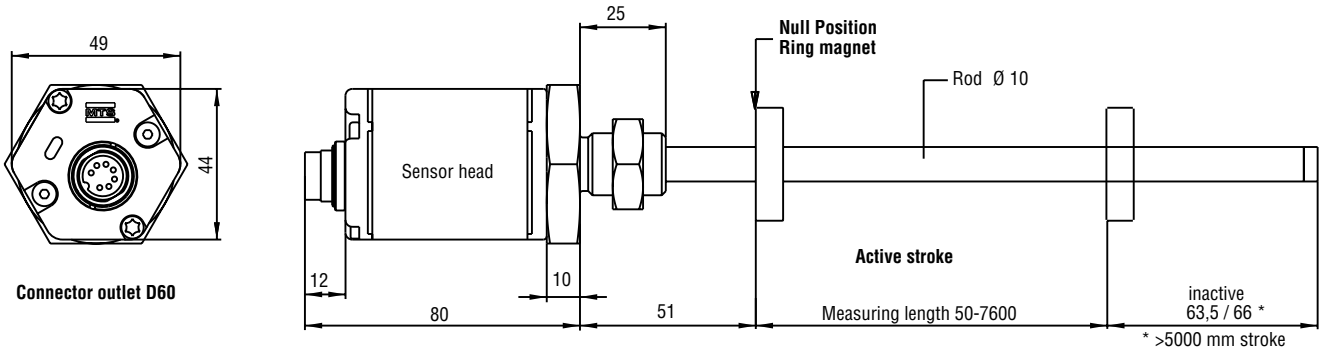

Selection of position magnet (not on delivery)

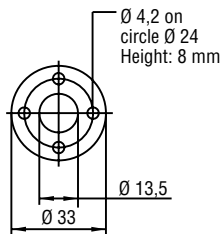

Ring magnet OD33
Part No. 201 542-2
Composite PA-Ferrite-GF20
Weigth ca. 14g
Operating temperature:
-40 ... +100°C

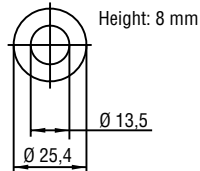

Ring magnet OD25,4
Part No. 400 533
Composite: PA-Ferrite
Weigth ca. 10g
Operating temperature:
-40 ... +100°C

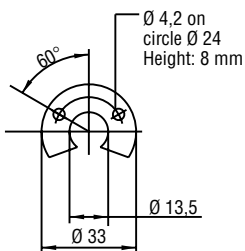

U-magnet M OD33
Part No. 251 416-2
Composite PA-Ferrite-GF20
Weigth ca. 11g
Operating temperature:
-40 ... +100°C

High Pressure Rod Design

Temposonics-RH with a pressure-resistant stainless steel flange and sensing rod is suitable for use in hydraulic cylinders and externally in all applications where space is a problem. Position measurement is via ring or U-magnets travelling along the sensing rod without any mechanical contact.

Advantage...
the completely operable sensor cartridge can be replaced for servicing easily without opening the fluid circuit.

Flexible installation in any position

Profile model

Normally, the sensor is firmly installed - fixed on a straight surface of the machine with movable mounting clamps or M5 screws in base channel - whilst the magnet is mounted at the mobile machine part.

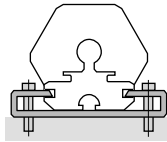

Mounting clamp with screws M5x20
Tightening torque: max. 5 Nm

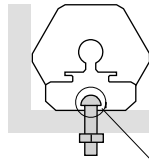

T-slot Nut in base channel

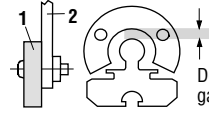
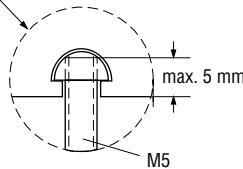

Do not exceed max. gap of 3 mm (± 1)

1 U-Magnet
2 Mounting plate and screws non-ferrous material

Rod model

Mount the sensor via flange thread or a hex nut. If possible, non-magnetizable material should be used for mounting support (dimensions as shown). With horizontal mounting, longer sensors (from 1 meter) must be provided with mechanical support.

Hydraulic sealing

Recommended is sealing of the flange facing with O-Ring (e.g. 22,4 x 2,65) in a cylinder cover nut or an O-Ring 15,3 x 2,2 in undercut.

Minimum assembly distance

1. Non-magnetizable material

2. Magnetizable material

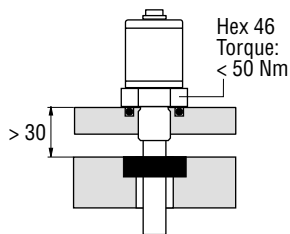

Recommended hydraulic sealing

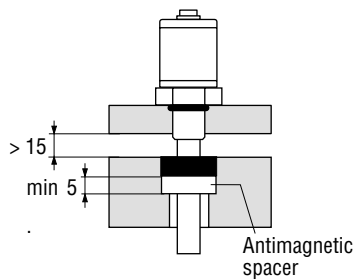

Alternative sealing
O-Ring 15,3 x 2,2

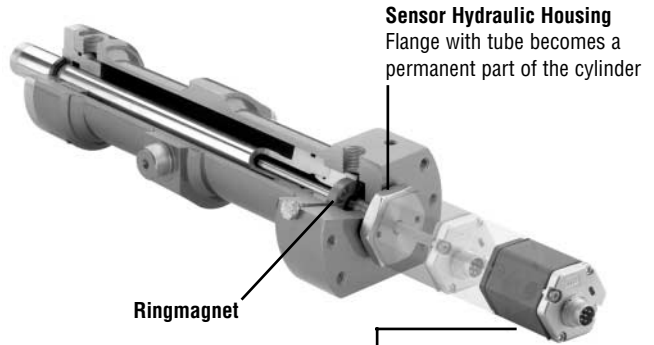

Sensor Cartridge
Electronic head + sensor element, easy to replace in field with two screws M4 (2,5 mm hexagon socket)

Cylinder installation

When used for direct stroke measurement in fluid cylinders, the sensor's high pressure, stainless steel rod installs into a bore in the piston head/rod assembly as illustrated. That guarantees a longlife and trouble-free operation - independent of used hydraulic fluid.

The sensor cartridge can be removed from the flange and rod housing while still installed in the cylinder. This procedure allows quick and easy sensor cartridge replacement, without the loss of hydraulic pressure.

Wiring

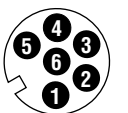

Male insert sensor plug rear of cable connector

Pin	Cable	Function
1	grey	Output 1: Position # 1 0...10 / 10...0 / -10...+10 / +10...-10 V 4(0)...20 / 20...4(0) mA
2	pink	DC Ground
3	yellow	Output 2: Position # 2 or Speed 0...10 / 10...0 / -10...+10 / +10...-10 V 4...20 / 20...4 mA
4	green	DC Ground
5	brown	+ 24 VDC (-15/+20 %)
6	white	DC Ground (0 V)

Cable connector (recommended, not on delivery)

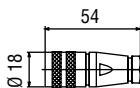

6 pin female connector M16, PG7
Part No. ST C0 9131 D

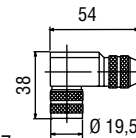

6 pin female connector M16, PG9
Part No. ST C0 9131 D06 PG9

6 pin 90° female connector M16
insert adjustable in 45° positions
Part No. ST C0 9131-6

Housing: Zinc nickel plated
Termination: Solder
Contact insert: Silver plated
Cable clamp: PG7
Max. Cable-Ø 6mm
Cable clamp: PG9, M16
Max. Cable-Ø 8 mm

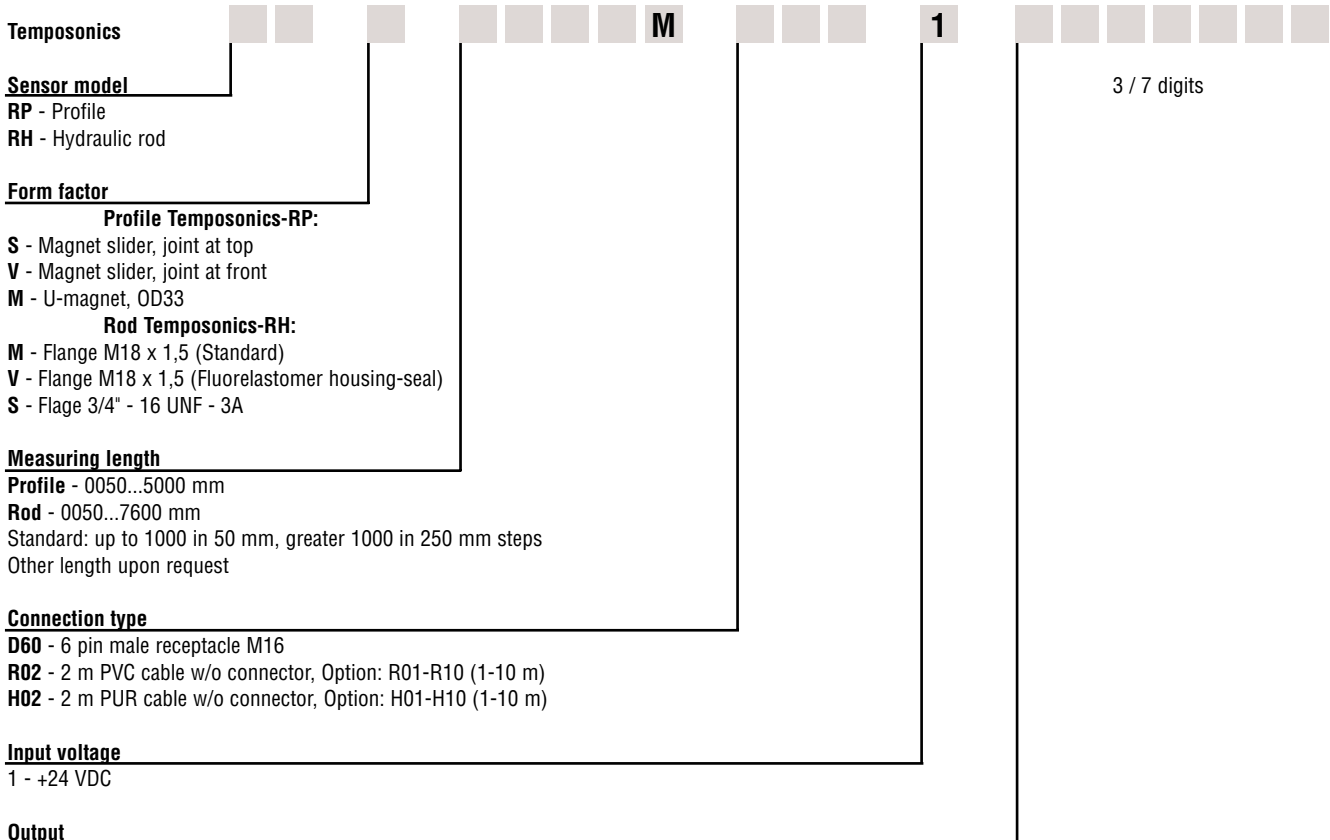

Output

1 Output with 1 Magnet

Output 1 (Position Magnet 1)

V01 = 0...10 V	A01 = 4...20 mA
V11 = 10...0 V	A11 = 20...4 mA
V21 = -10...+10 V	A21 = 0...20 mA
V31 = +10...-10 V	A31 = 20...0 mA

2 Outputs with 1 Magnet

Output 1 (Position Magnet 1) + Output 2 (Absolute Speed Magnet 1)

Magnet direction	>>>>	Head	Null	Tip
V01 xxx.x = 0...10 V		+10.....0.....+10 V		
V11 xxx.x = 10...0 V		+10.....0.....+10 V		
A01 xxx.x = 4...20 mA		20.....4..... 20 mA		
A11 xxx.x = 20...4 mA		20.....4..... 20 mA		

Output 1 (Position Magnet 1) + Output 2 (Speed Magnet 1)

Magnet direction	>>>>	Head	Null	Tip
V61 xxx.x = 0...10 V		-10.....0.....+10 V		
V71 xxx.x = 10...0 V		+10.....0.....-10 V		
A41 xxx.x = 4...20 mA		4.....12..... 20 mA		

Output 1 (Position Magnet 1) + Output 2 (Position Magnet 1)

V03 = 0...10 V	10 ... 0 V
-----------------------	------------

2 Outputs with 2 Magnets

Output 1 (Position Magnet 1) + Output 2 (Position Magnet 2)

V02 = 0...10 V	0 .. 10 V
V12 = 10...0 V	10...0 V
V22 = -10...+10 V	-10...+10 V
V32 = +10...-10 V	+10...-10 V
A02 = 4...20 mA	4...20 mA
A12 = 20...4 mA	20...4 mA

Fill in blanks (xxx.x) with desired max. speed (see above):

- **Speed range 1: 0,1...10 m/s (0001 ... 0100)**

Sample: (-5,5...0...5,5 m/s = 10...0...10 V) = V01 0055

- **Speed range 2: 25...90 mm/s (1025 ... 1090)**

Sample: (-50...0...50 mm/s = 4...12...20 mA) = A41 1050

Accessories (selection)

Magnet slider type »S«	Part No.	252 182
Magnet slider type »V«	Part No.	252 184
U-Magnet OD33, corresponding type »M«	Part No.	251 416-2
Ring magnet OD33, Standard	Part No.	201 542-2
Ring magnet OD25,4	Part No.	400 533
O-Ring 15,3 x 2,2 Fluorelastomer FPM 75	Part No.	401 133
Mounting clamp	Part No.	400 802
T-slot nut M5 for base channel mounting	Part No.	401 602
6 pin female cable connector M16, PG7	Part No.	STC 09131 D
6 pin female cable connector M16,	Part No.	STC 09131 D06 PG9
6 pin 90°-female cable connector M16,	Part No.	STC 09131-6
PVC-cable 3 x 2 x 0,14 mm ²	Part No.	K27
PUR-cable 3 x 2 x 0,25 mm ²	Part No.	K59

Accessories (selection)

MTS-Servicetools	Part No.	
Hand-Programmer R-Analog	Part No.	253 124
Cabinet Programmer	Part No.	253 408
PC-Programmer R-Analog, incl. power supply	Part No.	253 134
100 - 240 VAC / 24 VDC, connection cable and CD-ROM		

On delivery profile model: Sensor, Position magnet, 2 mounting clamps up to 1250 mm + 1 clamp for every additional 500 mm

On delivery rod model: Sensor, hex nut, pls. order magnet sparately.

www.mtssensor.de
www.temposonics-shop.de
Service Hotline: 01805 - mtssensor

© MTS Temposonics® R-Series Temposonics RPRH Analog 24032006e - Alterations reserved

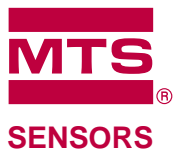

Germany
MTS Sensor Technologie
GmbH & Co. KG
Auf dem Schüffel 9
D-58513 Lüdenscheid
Tel.: +49-2351-9587-0
Fax: +49-2351-56491
info@mtssensor.de
www.mtssensor.de

USA
MTS Systems Corporation
Sensors Division
3001 Sheldon Drive
Cary, NC 27513, USA
Tel.: +1-919-677-0100
Fax: +1-919-677-0200
info@mtssensors.com
www.mtssensors.com

Japan
MTS Sensors Technology Corp.
Ushikubo Bldg.
737 Aihara-cho, Machida-shi
Tokyo 194-0211, Japan
Tel.: +81-42-775-3838
Fax: +81-42-775-5516
info@mtssensor.co.jp
www.mtssensor.co.jp