

G-Series SSI

Temposonics GB
Measuring length 50 - 3250 mm



Perfect data transmission
5 µm

- Absolute Sensor for Hydraulic Cylinders, without re-homing
- Stainless Steel Rod Sensor
- Contactless Sensing with Highest Durability
- Rugged Industrial Sensor, EMC shielded and CE certified
- Superior Accuracy: Linearity Tolerance better 0,02 %
- Repeatability 0,001 %
- Resolution up to 5 µm
- Direct 25/24 bit SSI output (Gray or Binary)

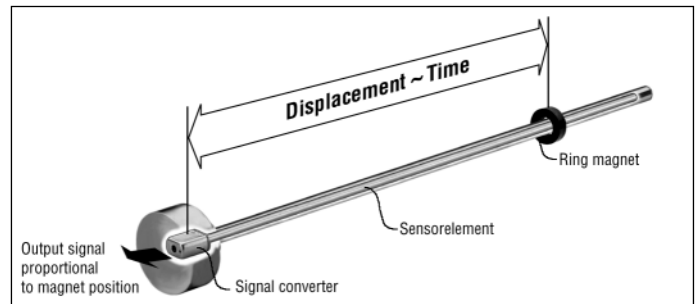

Magnetostriction

The absolute **Temposonics®** linear position sensors are based on the MTS developed magnetostrictive measurement principle. That combines various magneto-mechanical effects and uses the physical height precise speed-measurement of an ultrasonic wave (torsion pulse in its sensor element) for position detecting. Sensor integrated signal processing transforms the measurements directly into market standard outputs. The contactless principle - an external movable magnet marks the position - eliminates the wear, noise and erroneous signal problems and guarantees the best durability without any recalibration.

Form factor

These compact stainless steel position sensors are designed for installation into standard hydrocylinders, specifically for use with clevis head or any space limited cylinder applications.

Simple mechanics

- The sensor head accommodates the electronics with active signal conditioning
- The pressure-proof sensor pipe with fitting flange protects the internal sensor element. It fits into the bored piston rod.
- The position magnet - fixed at the piston bottom - drives wearfree over the sensor's stroke and starts the measurement signal through sensor rod wall.

Temposonics-GB Pressure Proof Sensor for Standard Hydrocylinders

The interface of Temposonics-GB linear sensors fulfil all requirements of the SSI standard for absolute rotary transducers. Its displacement value is encoded in a **25- or 24-bit Binary or Gray** code format and transmitted at very high speed via a serial type interface in **RS 422** standard to the control device. SSI provides effective synchronization in a closed-loop control system. A clock pulse train from a controller is used to gate out sensor data.

Measuring range

The output of position values are corresponding with the selected resolution scale. The start position of electrical stroke is here factory set at **40 mm**.

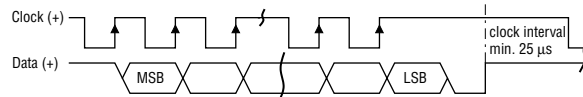
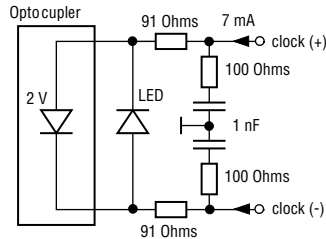

Measuring frequency

Measuring range:	300	750	1000	2000	3250 mm
Measurements/second:	3,7	3,0	2,3	1,2	0,8 kHz

Data transfer speed: 70 kBaud ... 1,5 MBaud

Depending on controller selected baud rate, following maximum cable length is permitted.

Cable length:	< 3	< 50	< 100	< 200	< 400 m
Baud rate:	1,5 MBd	< 400 kBd	< 300 kBd	< 200 kBd	< 100kBd

Example:

Resolution: 0,01 mm
Mounting zone: 40 mm
Measuring length: 300 mm
Measuring direction: forward

Measuring range

Start position = mm
Middle = 150 mm
End position = 300 mm
Start position, underflow
End position, small overflow
End position exceeded or position magnet error

Position value

4000 = 40 mm
19000 = 190 mm
34000 = 340 mm
< 4000 = < 40 mm
> 34000 = > 340 mm
Alarm value = 000000

Technical Data

Input	
Measuring Variable	Displacement
Measuring Range	50 - 3250 mm
Output	
Interface	SSI (Synchronous Serial Interface), RS 422 standard
Data format	Binary or Gray encodes
Data length	25 or 24 bit (upon request)
Accuracy	
Resolution	5/10/20/50/100 µm
Linearity	< ± 0,02 % F.S. (Minimum ± 60 µm)
Repeatability	< ± 0,001 % F.S.
Temperature coefficient	< 15 ppm/°C
Operating conditions	
Magnet speed	any
Operating temperature	-40° C ... +75° C
Pressure rating	350 bar, 700 bar peak
Enclosure	IP 67 if cable connector is correctly fitted
Shock rating	100 g (Single hit) / IEC-Standard 68-2-27
Vibration rating	5g / 10-150 Hz, IEC-Standard 68-2-6
EMC Test	Electromagnetic emission EN 61000-6-3 Electromagnetic immunity EN 61000-6-2 (EN 61326/A1) EN 61000-4, Criteria A, CE qualified EN 61000-4-2/3/4/6, Criterion A CE qualified
Form factor / Material	
Sensor head	Stainless steel 1.4305 / AISI 303
Rod with flange	Stainless steel 1.4301 / AISI 304
Magnet Type	Ring magnet, PA-Ferrit
Installation	
Mounting	Any orientation
Sensor mounting	Flange Ø18h 6, 6 screws (ISO 4762)
Electrical Connection	
Connection Type	7 pin connector M16 x 0,75 or cable outlet (PUR cable 3x2x0,25 mm ² , Ø 7,9 mm)
Input voltage	24 VDC (+20 % / -15 %)
- Polarity protection	Up to 30 VDC
- Overvoltage protection	Up to 36 VDC
Current consumption	50 - mA, stroke length dependent
Ripple	< 1 % peak to peak
Electric strength	500 V (DC ground to machine ground)

Any fitting position Simple mounting Small installation dimensions

The sensor's high-pressure, stainless steel tube with fitting flange will be fixed via 6 machine screws M6 x 16 x A2-70 (ISO 4762) through the bores in the sensor head. The hydraulic sealing requires the use of a supplied O-Ring 15 x 2. Using ferromagnetic supports, note that the magnet must be mounted with non-ferrous spacer and screws.

Position magnet

For accurate position measurements mount the magnet with non-ferrous fastening material (screws, supports ect.). Using ferromagnetic supports, note that the magnet must be mounted with non-ferrous spacer of 5 mm minimum and screws. Note the minimum mounting dimensions as illustrated right.

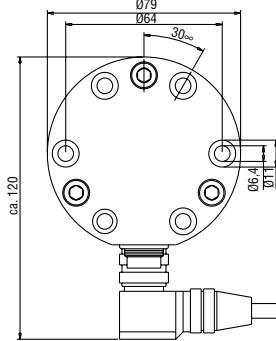
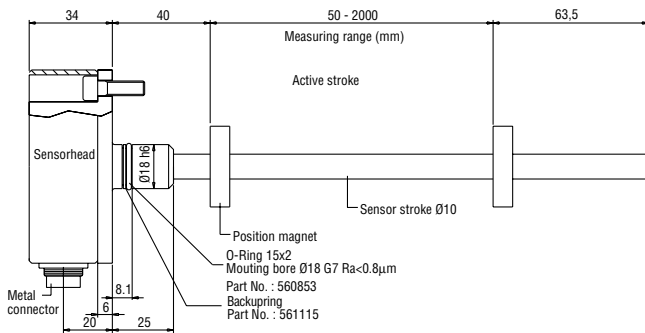
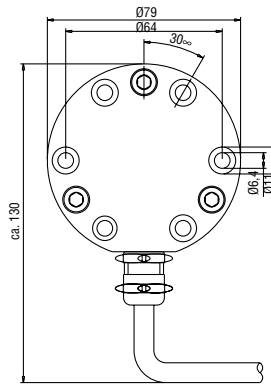
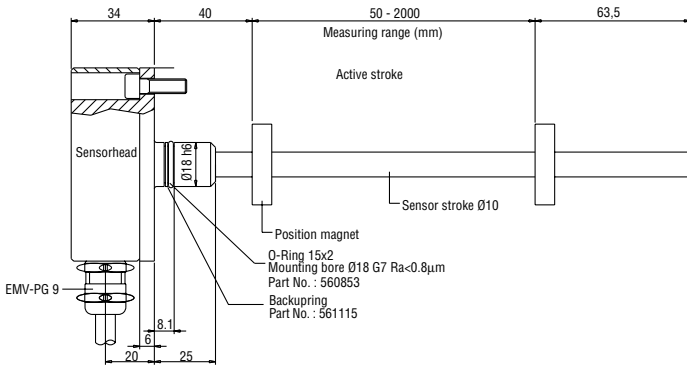

Position magnets

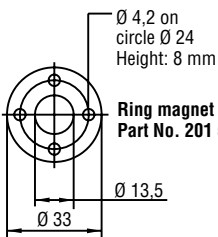

Ring magnet OD33
Part No. 201 542-2

Composite PA-Ferrite-GF20
Weigth ca. 14g
Operating temperature:
-40 ... +100°C

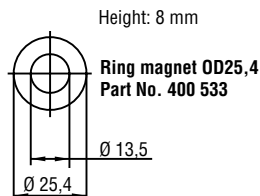

Ring magnet OD25,4
Part No. 400 533

Composite: PA-Ferrite
Weigth ca. 10g
Operating temperature:
-40 ... +100°C

Cylinder installation

Use a rod bush (e. g. teflon) to prevent wear on the magnet and the sensor pipe. The bore in the piston rod is dependent on hydraulic pressure and piston velocity ect. The minimum drilling must be 13 mm. Do not exceed the 700 bar peak pressure.

Wiring	Pin	Cable	Function
	1	Gray	Data (-)
	2	Pink	Data (+)
	3	Yellow	Clock (+)
	4	Green	Clock (-)
	5	Brown	+24 VDC
	6	White	0 V (GND)
	7	N.C.	

Note:

Application tht can damage the integral cable, please take connector output version. Sensor electronics and integral cable are encapsolated completely. Repairing electronic module is impossible.

Antimagnetic Support

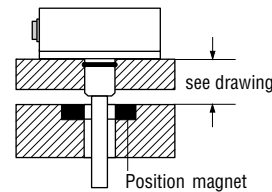

Magnetizable support

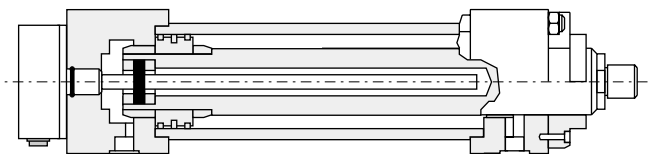
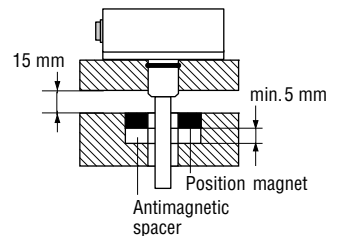

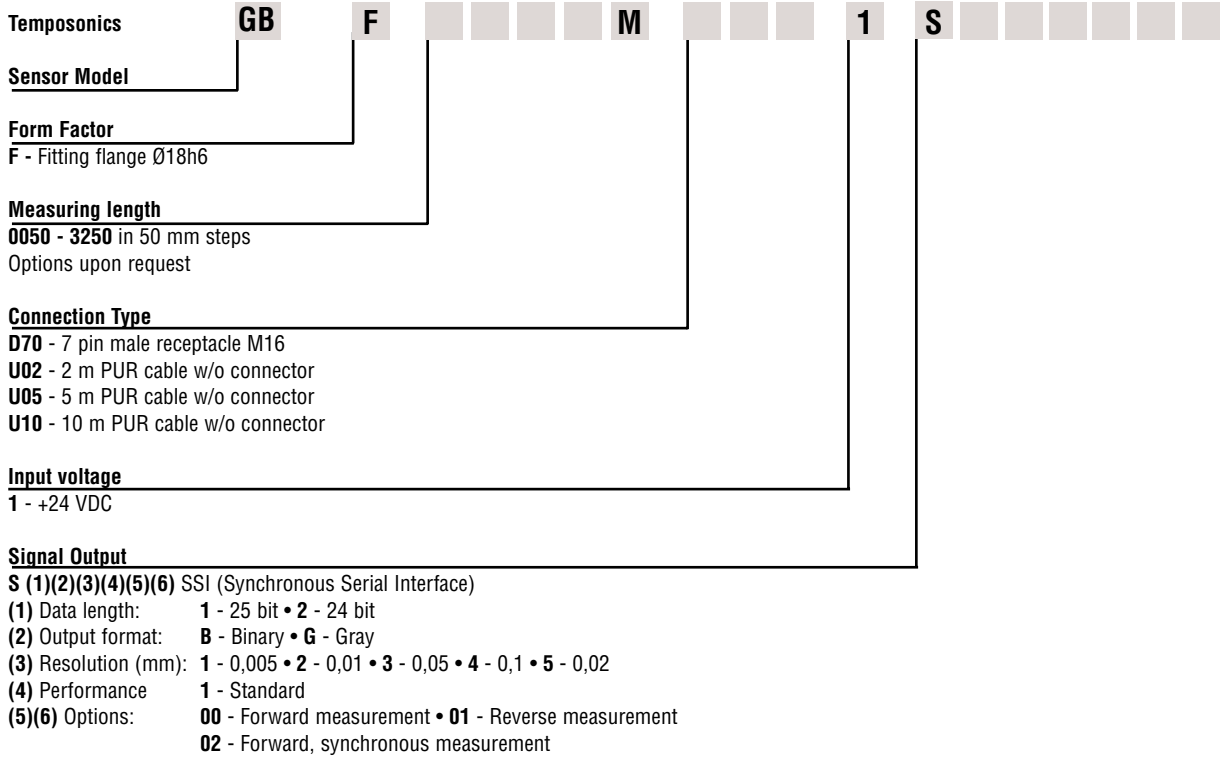

On Delivery
Sensor with O-Ring,
Magnet (below) must be ordered separately

Accessories (selected)	Description	Part No.
	Position magnet OD33	201 542-2
	Position magnet OD25,4	400 533
	7 pin female cable connector M16	ST C0 9131 D07 PG9
	7 pin 90° female cable connector M16	ST C0 9131-7
	PUR cable 3x2x0,25 mm ²	K57
	O-Ring 15 x 2 Fluorelastomer FPM 75	560 853
	Backup ring	561 115
MTS-Service tools:		
	PC-Programmer R-SSI incl. power supply (100-240 VAC/24 VDC), connection cable and programming software (CD)	253 135
	SSI display and control unit (96x48x150 mm)	IX 340

Cable connector
(recommended, not on delivery)

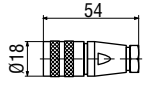

7 pin female cable connector M16
Part No. ST C0 9131 D07 PG9

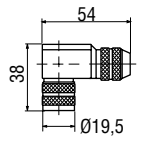

7 pin 90° female cable connector M16
Part No. ST C0 9131-7

Housing: Zinc, nickle plated
Termination: Solder
Contact Insert: Silver plated
Cable clamp: PG9
Cable-Ø: 8 mm

www.mtssensor.de
www.temposonics-shop.de
Service Hotline: 01805 - mtssensor

© MTS Temposonics® G-Series Temposonics GB SSI 20102005e - Alterations reserved

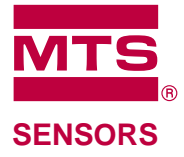

Germany
MTS Sensor Technologie
GmbH & Co. KG
Auf dem Schüffel 9
D-58513 Lüdenscheid
Tel.: +49-2351-9587-0
Fax: +49-2351-56491
info@mtssensor.de
www.mtssensor.de

USA
MTS Systems Corporation
Sensors Division
3001 Sheldon Drive
Cary, NC 27513, USA
Tel.: +1-919-677-0100
Fax: +1-919-677-0200
info@mtssensors.com
www.mtssensors.com

Japan
MTS Sensors Technology Corp.
Ushikubo Bldg.
737 Aihara-cho, Machida-shi
Tokyo 194-0211, Japan
Tel.: +81-42-775-3838
Fax: +81-42-775-5516
info@mtssensor.co.jp
www.mtssensor.co.jp