

E-Series Analog + Start / Stop

Temposonics EP

Measuring range 50 - 1500 mm / 50 - 3250 mm

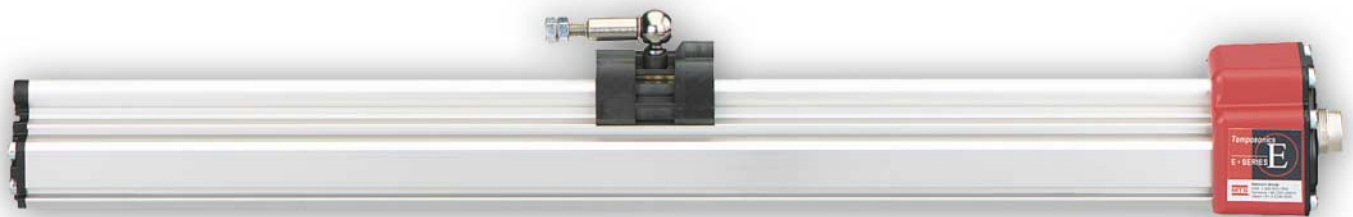

... innovative Sensor-Parameter Handling

- Linear, Absolute Measurement
- Contactless Sensing with Highest Durability
- Rugged Industrial Sensor, EMC shielded and CE certified
- High-Precision: Linearity better 0,02 %
- Repeatability 0,001 %
- Direct Position Outputs:
 - Analog (V/mA)
 - Start / Stop + Sensor-Parameter Upload
- Measuring Range 50 - 1500 mm / 50 bis 3250 mm

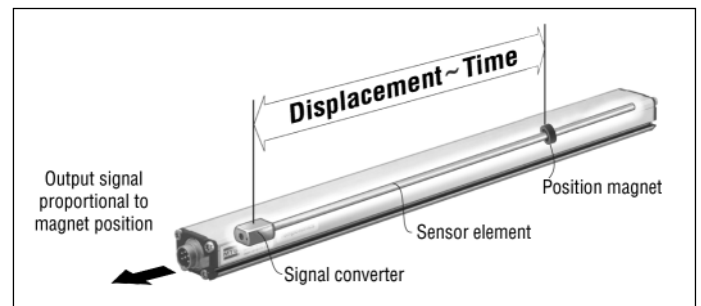

Magnetostriction

The absolute **Temposonics®** linear position sensors are based on the MTS developed magnetostrictive measurement principle. That combines various magneto-mechanical effects and uses the physical height precise speed-measurement of an ultrasonic wave (torsion pulse in its sensor element) for position detecting. Sensor integrated signal processing transforms the measurements directly into market standard outputs. The contactless principle - an external movable magnet marks the position - eliminates the wear, noise and erroneous signal problems and guarantees the best durability without any recalibration.

Form factor

Temposonics® are extremely robust sensors, ideal for continuous operation under harshest industrial conditions. The sensor is completely modular in mechanics and electronics design.

- A profile **sensor housing** protects the sensor element in which gives rise to the measurement signal.
- The **sensor head**, a solid diecast aluminum housing, accommodates the complete modular electronic interface with active signal conditioning. Double encapsulation ensures high operating safety and optimum EMC protection.
- The external **position transmitter** is a permanent magnet. It is fitted at the mobile machine part, taken over the sensing

Temposonics-EP

Analog + Start / Stop

Temposonics-EP

A stable profile version

Measuring range: 50 - 1500 mm
50 - 3250 mm (Start / Stop output R3)

A robust aluminum profile offers modular construction, flexible mounting configurations, and easy installation. Position measurement is contactless via two versions of permanent magnets.

- A captive sliding magnet running in profile housing rails. Connection with the mobile machine part is via a ball jointed arm to taking up axial forces.
- A floating magnet, mounted directly on the moving machine part, travels over the profile at a low distance. Its permissible misalignment allows a not completely parallel installation.

Technical Data

Input	
Measured variable	Displacement
Measuring range	50 - 1000 mm / 50 - 3250 mm for start/stop output R3
Output	
1. Voltage	0 - 10 VDC or 10-0 VDC (Controller input resistance RL: > 5 kOhm)
2. Current	4 - 20 mA or 20-4 mA, (Min./max. load: 0...500 Ohm)
3. Start/Stop	RS-422 differential signal, additional available: <u>Serial</u> parameter upload of Measuring range, Offset, Gradient (Ultrasonic speed of sensing pulse), status and manufacturer number
Accuracy	
Resolution	Analog: Infinite Start/Stop: 0,1 / 0,01 / 0,005 mm
Linearity, uncorrect	< ± 0,02 % F.S. (Minimum ± 60 µm)
Repeatability	< ± 0,001 % F.S.
Update frequency	Analog: > 1,5 kHz / Digital: controller dependent
Ripple	< 0,01 % F.S. / Digital: controller dependent
Operating Condition	
Mounting position	Any
Magnet speed	Any
Operating temperature	-40° C ... +75° C
Dew point, humidity	90 % rel. humidity, no condensation
Ingress protection	IP 65 if mating cable connector is correctly fitted
Shock rating	100 g (Single hit) / IEC-Standard 68-2-27
Vibration test	10 g / 10 - 2000 Hz / IEC-Standard 68-2-6
EMC Test	Electromagnetic emission EN 50081-1 Electromagnetic immunity EN 50082-2 EN 61000-4-2/3/4/6, Criteria A / CE qualified
Form factor / Material	
Sensor head	Aluminum
Sensor housing	Aluminum
Position magnet type	Magnet slider
Installation	
Mounting type	Adjustable mounting clamps
Electrical connection	
Connection type	6 pin connector M16
Input voltage	24 VDC (+20 % / -15 %)
Current consumption	50 - 140 mA (Digital 50 - 100 mA), stroke length dependent
Ripple	< 1 % s-s
Electric strength	500 V (0 V ground to machine ground)
Polarity protection	Up to -30 VDC
Overvoltage protection	Upt to 36 VDC

Analog output

Temposonics-EP are provided with an integrated analog interface and can be connected to a control system or indicator directly without an interface. The microelectronics in the sensor head generates continuous, strictly displacement proportional voltage and current outputs whose upscale or downscale output action can be selected when ordering. The output variables are factory-set. Recalibration is not necessary.

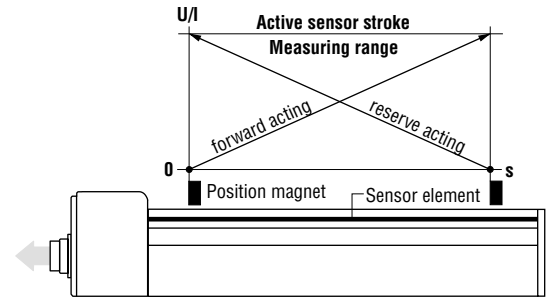

- Analog**
- 0-10 V
 - 10-0 V
 - 4-20 mA
 - 20-4 mA

START/STOP output

Digital Temposonics-EP is equipped with a start/stop output. The sensor requires a start signal from an external indicator in the control system and returns a signal corresponding to the magnet position. The time elapsed between the two signals is proportional to the magnet position, i.e. to the displacement. Time measurement is by the indicator and used for calculating the position value.

For easy adaption to user's control systems, following sensor parameter.

- Measuring range
- Offset
- Gradient
- Status
- Manufacturer number

can be read into controller without additional wiring. It can be done simply by using the standard signal outputs.

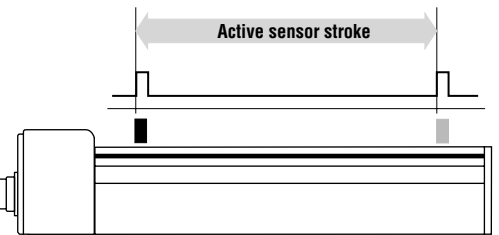
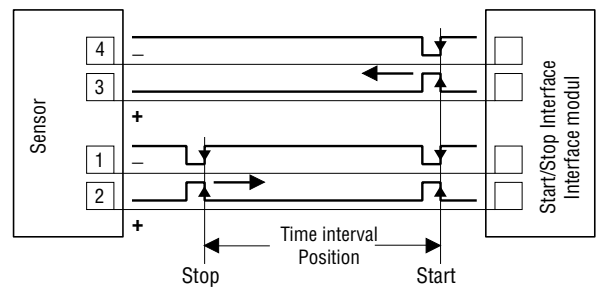

- Start/Stop + Parameters Upload**
- Measuring range
 - Offset
 - Gradient
 - Status
 - Manufacturer number

Linearity protocol

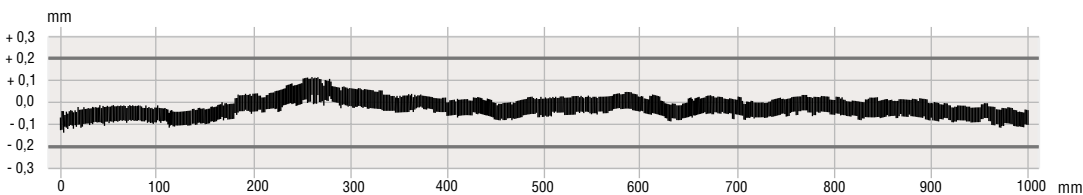

Sensor Temposonics-EP, measuring range 1000 mm
Tolerance allowed: ± 0,2 mm
Tolerance measured: typical ± 0,09 mm, uncorrected

Temposonics-EP

Analog + Start / Stop

Profile

The sensor is fixed on a straight surface of the machine with the movable mounting clamps. These are provided in stroke length dependent number and are evenly on the profile to be distributed. We recommend screws M5 x 20 (DIN 6912) for attachment with a torque of max. **5 Nm** to be tightened.

ATTENTION!

The EP sensor is now fixed isolated from machine ground. It is necessary that sensor housing is grounded with flat pin terminal on the sensor head **(1)**.

Position transmitter

U-Magnet: For accurate position measurements mount the magnet **(1)** with non-magnetizable fastening material **(2)** (screws, supports etc.).

Using magnetizable supports, note that the magnet must be mounted with non-ferrous **(3)** of 5 mm minimum and screws.

Block magnet: The magnet **(4)** can be fixed with standard material and screws **(5)**. Note the clearance, as shown right.

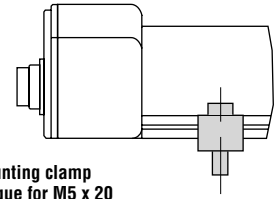
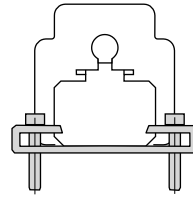

Sliding mounting clamp
Tightening torque for M5 x 20
machine screws: max. 5 Nm

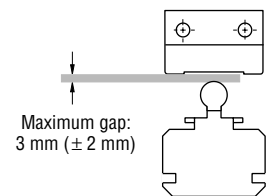
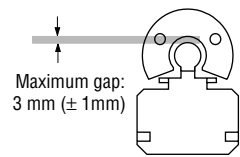
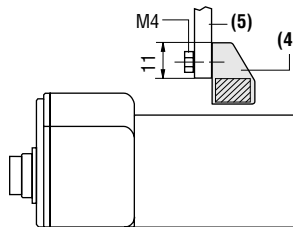
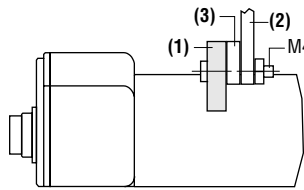
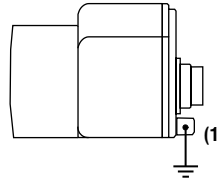

Attention!
do not exceed the allowed maximum gap

Wiring

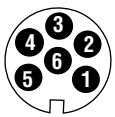

Front face of sensor plug
or rear of cable connector

Connector D60	Cable*	Analog (V)	Analog (mA)	Start/Stop
Pin 1	grey	0...10 V	4-20 mA*	Stop (-)
Pin 2	pink	DC Ground	DC Ground	Stop (+)
Pin 3	yellow	10...0 V	20 - 4 mA*	Start (+)
Pin 4	green	DC Ground	DC Ground	Start (-)
Pin 5	brown		+24 VDC (-15/+20%)	
Pin 6	white		DC Ground (0V)	

- * **Accessory:** Cable assembly with
- Cable connector, female (page 6)
 - Cable K27 (LiYCMY 3 x 2 x 0,14 mm²)

Cable shield is soldered on connector housing and must be grounded in the control unit.

*Only ordered current output is available.

Temposonics-EP

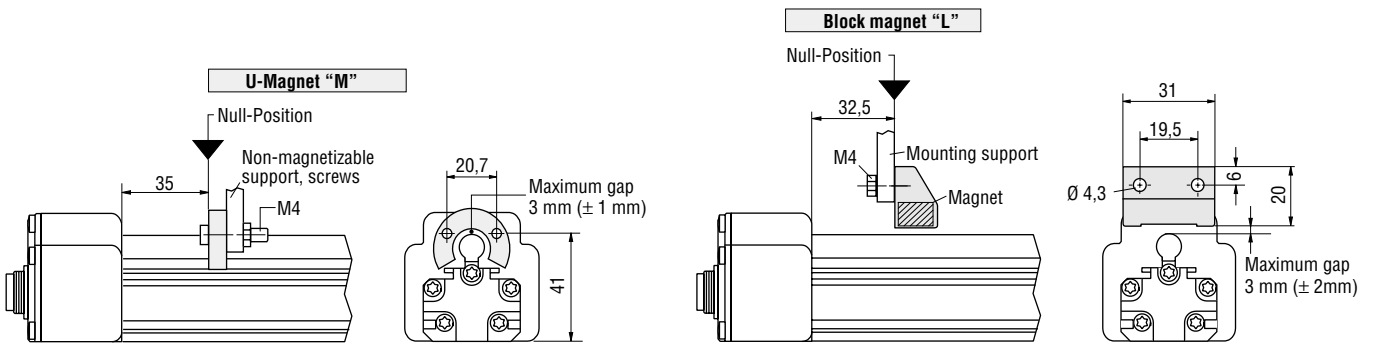
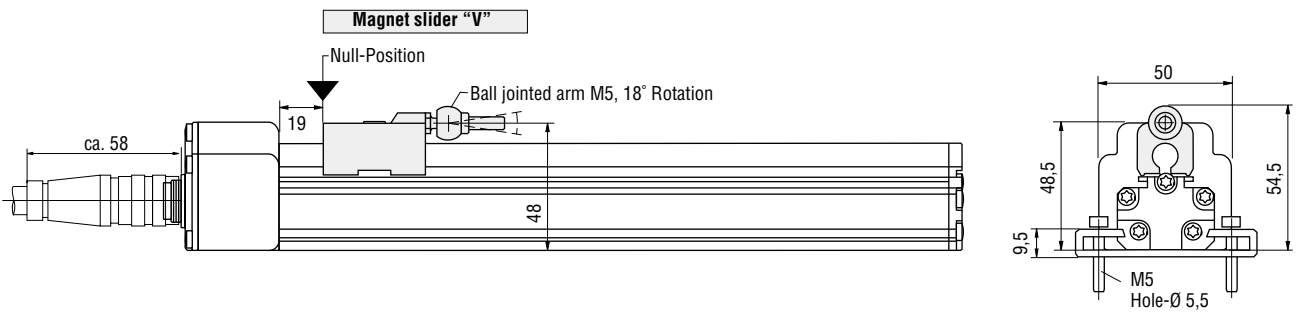
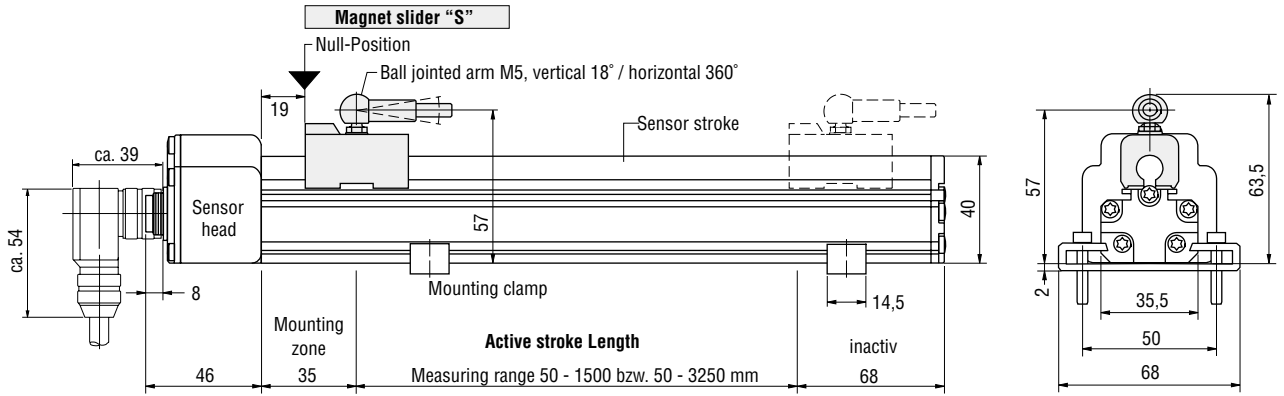

Connector outlet D60

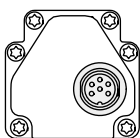

6 pol. Gerätestecker M16

Temposonics-EP

Analog + Start / Stop

Position transmitter

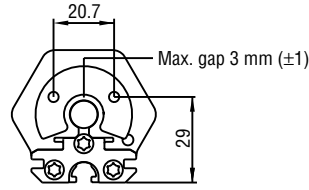
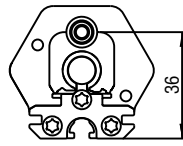
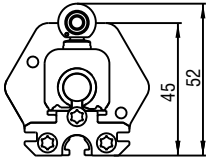

Magnet slider S
Part No. 252 182

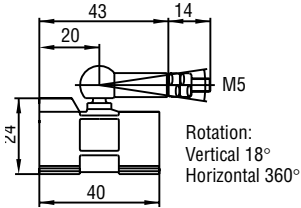

GFK, Magnet Hartferrit
Weight ca. 30 g
operating temperature: -40 ... +75°C

Magnet slider V
Part No. 252 184

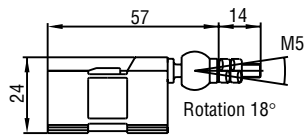

GFK, Magnet Hartferrit
Weight ca. 30 g
Operating temperature: -40 ... +75°C

U-Magnet M OD33
Part No. 251 416-2

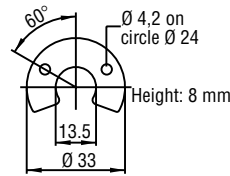

PA-Ferrit-GF20
Weight ca. 11g
Operating temperature: -40 ... +100°C

Block magnet L
Part No. 252 887

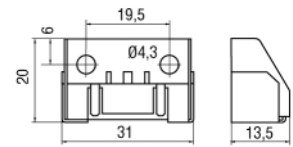

Bracket: CuSN6 zinc coated
Magnet: Hartferrit
Weight: ca. 20g
Operating temperature: -40...+75°C

Other magnets upon request

Cable connector (recommended, not on delivery)

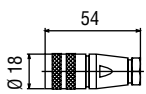

6 pin female connector M16, PG7
Part No. ST C0 9131 D

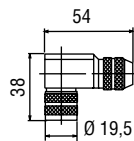

6 pin 90° female connector M16
insert adjustable 45° positions
Part No. ST C0 9131-6

Housing: Zinc, nickel plated
Termination: Solder
Contact insert: Silver plated
Cable clamp PG7/M16:
Max. cable-Ø 6 mm
Max. cable-Ø 8 mm

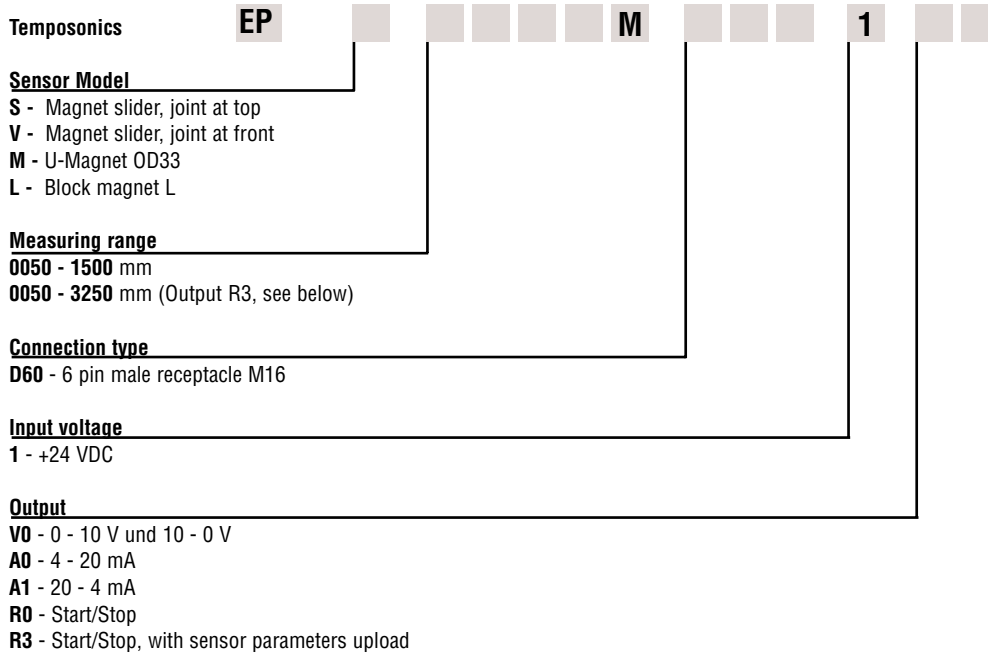

Scope of Delivery:

- Sensor
- 1 Captive sliding magnet or floating magnet
- 2 mounting clamps up to 1250 mm stroke
- + 1 Mounting clamp for 500 mm each

Please order accessories separately!

Measuring range:

Standard:
 Up to 1500 mm in 50 mm steps
 Upt to 1500 mm in 250 mm steps
 Option: Other lengths upon request

Accessories

Discription	Part No.
Magnet slider type "S"	252 182
Magnet slider type "V"	252 184
U-Magnet "M" OD33	251 416-2
Block magnet L	252 887
Mounting clamp	400 802
6 pin female cable connector M16	ST C0 9131 D
6 pin 90° cable connector M16	ST C0 9131-6
PVC-Cable 6 X 0,14 mm ²	K27

Temposonics-EP

Analog + Start / Stop

www.mtssensor.de
www.temposonics-shop.de
Service Hotline: 01805 - mtssensor

© MTS Temposonics® E-Series Temposonics EP Analog + Start / Stop 22032006e - Alterations reserved

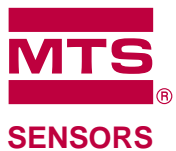

Deutschland
MTS Sensor Technologie
GmbH & Co. KG
Auf dem Schüffel 9
D-58513 Lüdenscheid
Tel.: +49-2351-9587-0
Fax: +49-2351-56491
info@mtssensor.de
www.mtssensor.de

USA
MTS Systems Corporation
Sensors Division
3001 Sheldon Drive
Cary, NC 27513, USA
Tel.: +1-919-677-0100
Fax: +1-919-677-0200
info@mtssensors.com
www.mtssensors.com

Japan
MTS Sensors Technology Corp.
Ushikubo Bldg.
737 Aihara-cho, Machida-shi
Tokyo 194-0211, Japan
Tel.: +81-42-775-3838
Fax: +81-42-775-5516
info@mtssensor.co.jp
www.mtssensor.co.jp