

Conveyor Belt Misalignment Switch

VG

Leaflet No. Kiepe 175



APPLICATION

Kiepe Belt Misalignment Switches are used in conveyor installations for monitoring the true running of conveyor belts. The switches, when mounted at the running edges of a conveyor belt, will be operated if the belt deviates from its designed running line by more than a permissible distance.

The switches will then stop the conveyor drive, avoiding spillage of material or damage to the plant. The Belt Misalignment Switches can be optionally supplied with a pre-alarm position for an alert signal at slight deviation and a final cut-out and lock. All switches are maintenance free. The device is intended for use in stationary installations and in vehicles.

PRODUCT DESCRIPTION

The switch enclosure consists of corrosion-resistant aluminium alloy. All external parts are either of stainless steel or have been especially plated. The actuating roller is of polyamide. All VG-types are fitted with snap acting switches. The actuating head is removable from the main switch body and may be re-fitted in any of four positions. This, together with re-positioning of the switch trip bar allows the actuating roller to operate in any of four directions giving greater mounting versatility. All this will insure extremely safe operation, permitting to use the switch for severe operation and in outdoor installations.

No maintenance will be required. For the Models VG.../5 and 6 the switching point has been set at the manufacturer's plant to approx. 12° from vertical and can be continuously readjusted in the field. The Model VG.../6 switch will latch as the admissible amount of out-of-line running is exceeded. It is unlatched locally by resetting the actuating roller. The VG 133/6 switch is equipped with two snap acting switches. An alert signal will be provided at approx. 12°, the final cut-out and latch will occur at 45°. For unlatching, the actuating roller is reset by hand.

SELECTION TABLE

Type Ref.	Pre-Alarm not included/included	Latching not included/included	No. of Contacts Switching Point at				Order number	Weight kg/each	
			15°		45°				
			NC	NO	NC	NO			
VG 03/5	X	X	1	1			92.038 143.501	0,75	
VG 033/5	X	X	2	2			92.038 143.511	0,75	
VG 03/6	X		X	1	1		92.038 143.601	0,75	
VG 033/6	X		X	2	2		92.038 143.611	0,75	
VG 133/6		X	X	1	1	1	1	92.038 143.615	0,75

Spares and Options

Actuating roller for type VG Ø 25 mm	94.037 860.001
Switch element for type VG	215.15.14.01.00
Ventilation duct	580.00.16.01.01

TECHNICAL DATA

Device complies with	EN 60947-5-1 EN 60204 VDE 0110
Enclosure	Aluminium alloy GK-ALSi 12
Finish	2 - Component DD - tile enamel, yellow
Fastening	By means 2 oblong holes for M6 bolts
Cable Entry	3 x M20 x 1,5
Protection	IP 65 according to EN 60529
Rated Insulation Voltage U_i	AC 380 V / DC 440 V
Earthing	Within Enclosure M5
Admissible Ambient Temperatures ¹⁾	-25 °C ... +70 °C
Switching Elements	Snap acting Switches
Number of Contacts	1 NC + 1 NO or 2 NC + 2 NO
Conventional Thermal Current I_{th}	10 A
Breaking Capacity I_e/U_e	5 A / AC 250 V
Operation per Hour	1500
Connections	Screw clamp terminals for a wire gauge of 2,5 mm ²
Mechanical Life	3 x 10 ⁶ Switching Cycles
Type of Operation	Actuating Roller; with or without latch
Actuating Roller	Polyamid 25 mm diameter
Switching Point	At approx. 12° from vertical. With devices designed for pre-alarm, this alarm will be tripped at approx. 12° without latching action, whereas cut-out will occur at 45°, with the device then being latched
Excursion	90° max.
Mounting Position	vertical
Maintenance free Options	Ventilation duct to avoid condensation

¹⁾ Deviating ambient temperature upon request

TECHNICAL DATA

Terminal Markings corresponding to DIN EN 50013

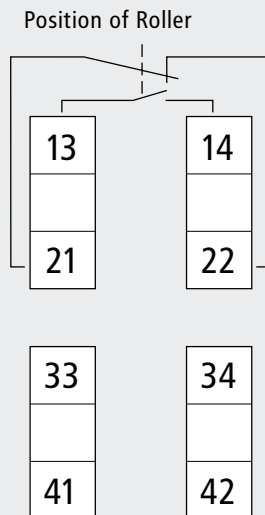

DIMENSIONS

maximum range of operation

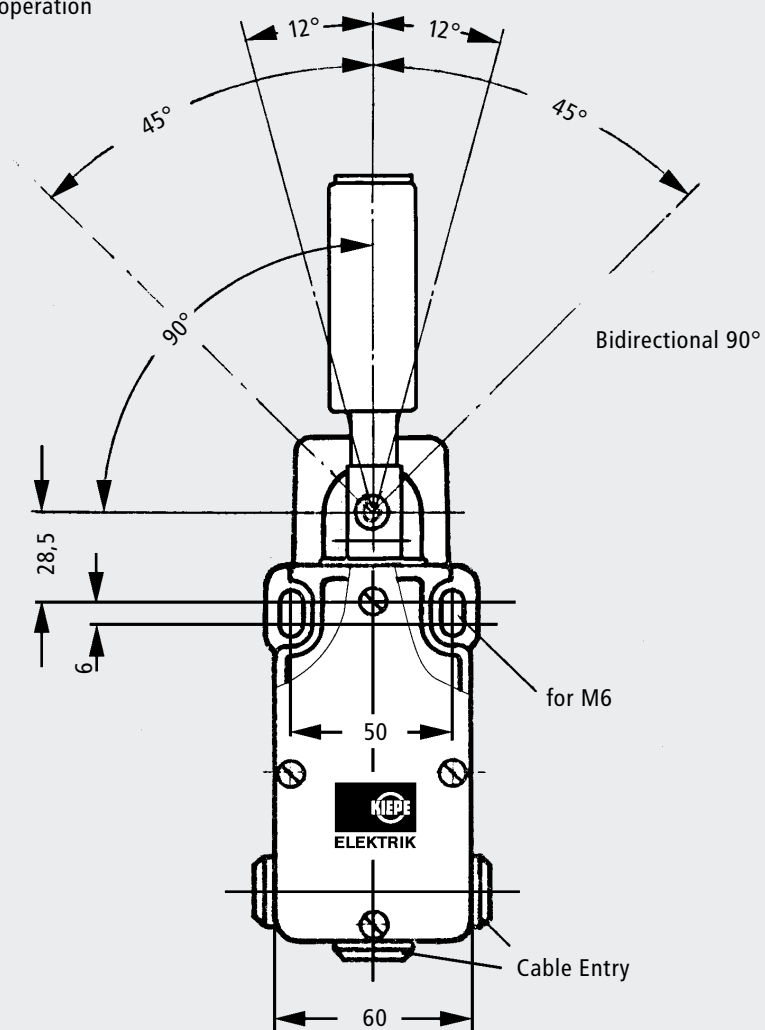

DIMENSIONS

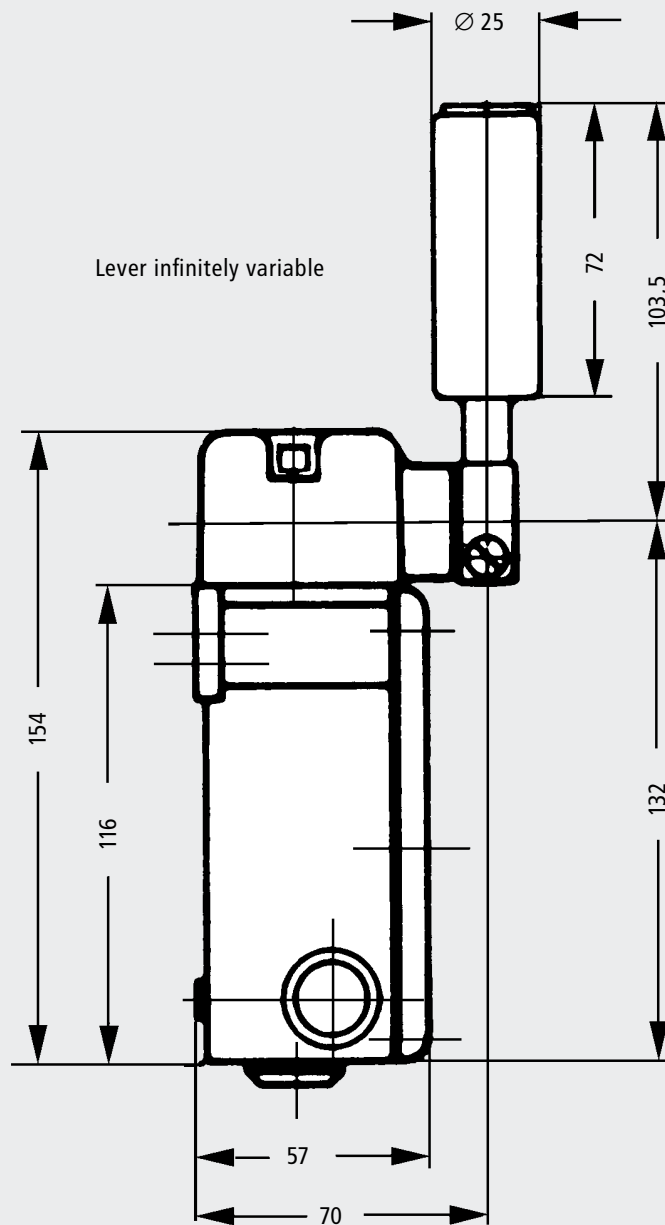

Subject to change without notice.