

Speed Monitor

SWE-compact

opto-electronic

Leaflet No. **Kiepe 114**



GENERAL

The electronic rotational speed monitor SWE-compact comprises constructively the opto-electronic pulse transducer, the speed analysing relay and the power supply in one unit. By this compact form of construction, the connecting wires between the pulse transducer and the analysing relay which are susceptible to interferences considering the usual electronic speed monitoring

systems, are eliminated. Only the supply voltage as well as the cables for the voltage-free output relay contacts need to be connected to the SWE-compact.

Electronic rotational monitoring of underspeed, control of slip, stand-still monitoring.

INSTALLATION AND OPERATION

The unit has a separate chamber containing the connection terminals, the knob of the setpoint potentiometer, the LED as well as the knob of the start-up delay potentiometer.

If the drive speed exceeds the pre-set operating speed, the relay is energized and the LED is lit. If the drive speed falls below the pre-set operating speed, the relay drops. The LED is extinguished.

An opto-coupler can be provided instead of the output relays.

The SWE-compact has the same fixing dimensions as the approved devices type SWS, DKS and EOGS. All the couplings and accessories of the devices can be used. For conveyors, speed

monitoring can be effected directly from the conveyor by means of the SWE-compact with coupled conveyor monitor stand and belt drive „B“.

Decisive features of the SWE-compact are:

Entirely free of maintenance, interference proof transmission of signals even over extremely long distances, simple and cost-saving setting up, monitoring of lowest rotating speeds (stand-still monitoring) and, above all, its compact construction especially planned for the operation under very rough service conditions.

The device is intended for use in stationary installations and in vehicles.

TECHNICAL DATA

Device complies with	EN 60204 EN 50178-94 EN 50081-1 EN 50082-2
Supply voltage	230 V ± 10%, 50 ... 60 Hz (other voltages on request)
Reset differential	≤ 20% from cut-out speed to cut-in speed
Trip point accuracy	< 2 %
Start-up delay	0,5 ... 15 sec., adjustable
Pick-up time	Of the output relay is 200 ms after the cut-in of the actuating supply voltage
Ambiente temperature	-20 °C ... +70 °C
Mounting position	Any
Protection	IP 65 according to EN 60529
Cable entry	2 x M25 x 1,5
Housing material	Aluminium alloy GK-AISI 12
Output contact	Single pole changeover goldplated contacts
Contact ratings I _e /U _e	2 A/AC 230 V

SPEED SELECTION

Type	Number of Imp./Rev.	Range of set point adjustment rpm	Cut-out delay sec.
SWE 001	1	40 - 600	2,5 - 1,1
SWE 005	5	8 - 120	2,5 - 1,1
SWE 010	10	4 - 60	2,5 - 1,1
SWE 025	25	1,6 - 24	2,5 - 1,1

When used in conjunction with the conveyor monitor type B the operating speed can be converted into rpm by the following formulae:

$$\frac{\text{belt speed in meters/sec.} \times 60}{0,314} = \text{rev./min.}$$

COUPLINGS

K1

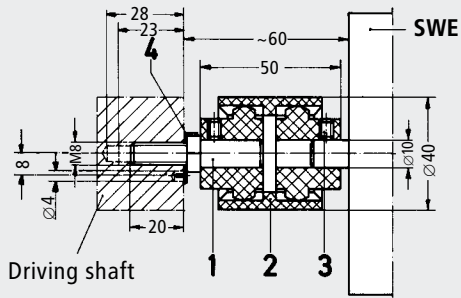

Ordering code: 94.040 535.001

Flexible plastic coupling,
temperature range about -25 °C to +100 °C,
weatherproof, maximum misalignment 3 mm

- 1) Connection shaft
- 2) Coupling
- 3) M5 x 6 Grub screw
- 4) 8,4 Locking washer

K6

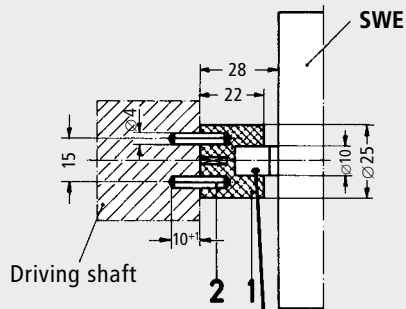

Ordering code: 94.040 535.002

Two-pin rubber coupling, oil-resistant,
maximum misalignment 2 mm

- 1) Coupling
- 2) Roll pin 4 x 20

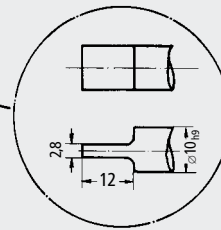

K7

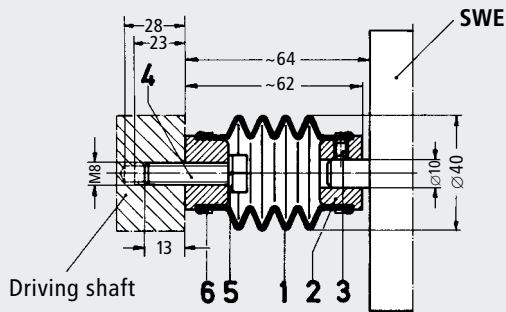

Ordering code: 94.040 535.004

Flexible bellows coupling suitable for poor
misalignment, maximum misalignment 10 mm

- 1) Bellows
- 2) Fixing collar
- 3) M5 x 6 Grub screw
- 4) Hexagon headed M8 x 30 screw
- 5) Spring retaining ring B 8
- 6) Retaining strap

CONNECTION DIAGRAM

SWE (cover replaced)

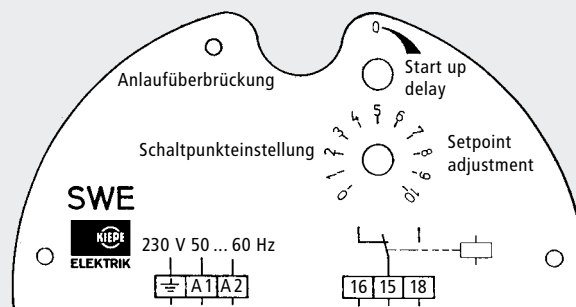

MOUNTING DETAILS & ORDERING CODES

Rotational Speed Monitor **SWE** compact

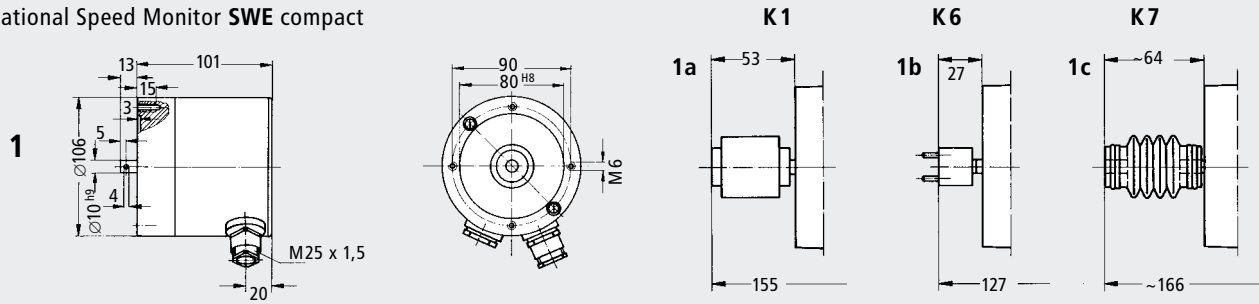

	Type number	Type of mounting	Type of coupling
1	SWE	-2	
1a	SWE	-2	/K1
1b	SWE	-3	/K6
1c	SWE	-2	/K7

Rotational Speed Monitor **SWE** compact with foot mounting bracket F4

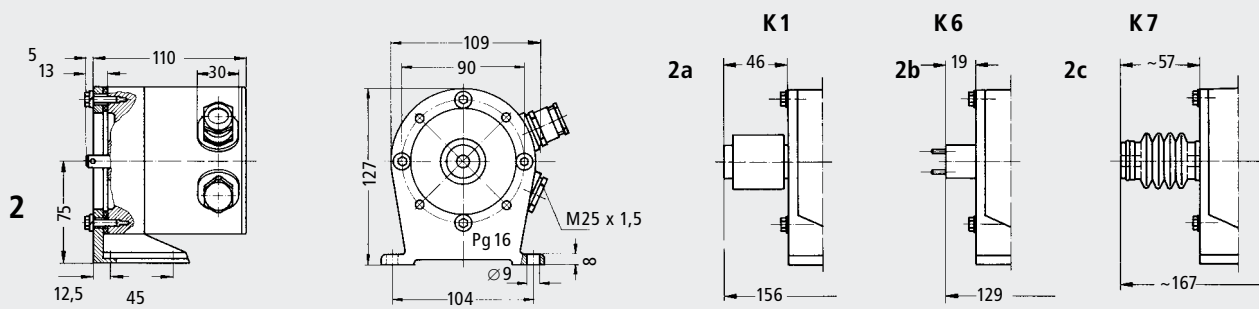

	Type number	Type of mounting	Type of coupling
2	SWE	-2	/F4
2a	SWE	-2	/K1
2b	SWE	-3	/K6
2c	SWE	-2	/K7

Rotational Speed Monitor **SWE** compact with mounting flange F1

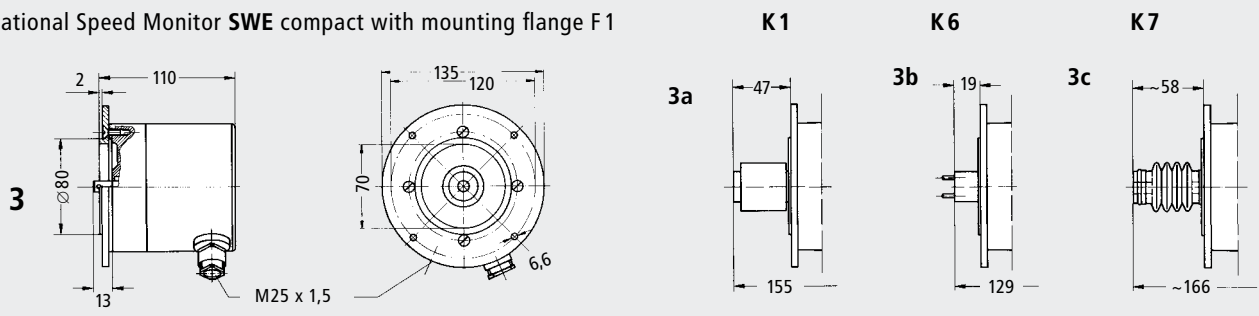

	Type number	Type of mounting	Type of coupling
3	SWE	-2	/F1
3a	SWE	-2	/K1
3b	SWE	-3	/K6
3c	SWE	-2	/K7

Rotational Speed Monitor **SWE** compact with mounting flange F2

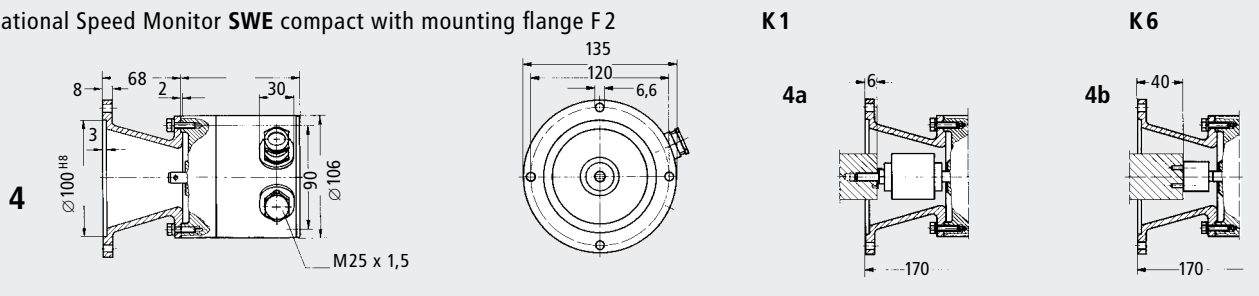

	Type number	Type of mounting	Type of coupling
4	SWE	-2	/F2
4a	SWE	-2	/K1
4b	SWE	-3	/K6

DIMENSIONS AND ORDERING CODES

Conveyor Drive Model SWEB

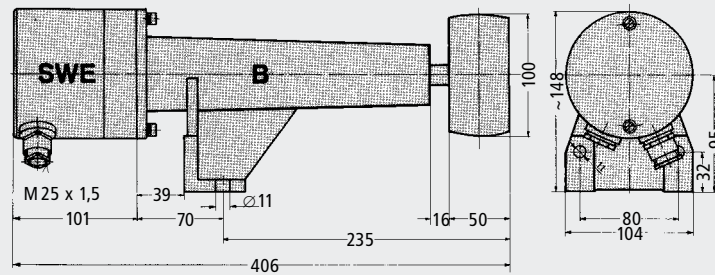

	Type Number	Housing (IP 65) ¹⁾	Roller ²⁾
	_____ -2	/S	/...
	_____ -2	/S	/...
	_____ -2	/S	/...
	_____ -2	/S	/...

1) S: Aluminium 2) G: Rubber, K: Plastic

DIMENSIONS

Hinge Pedestal Type GB to be fitted on Belt Drive B

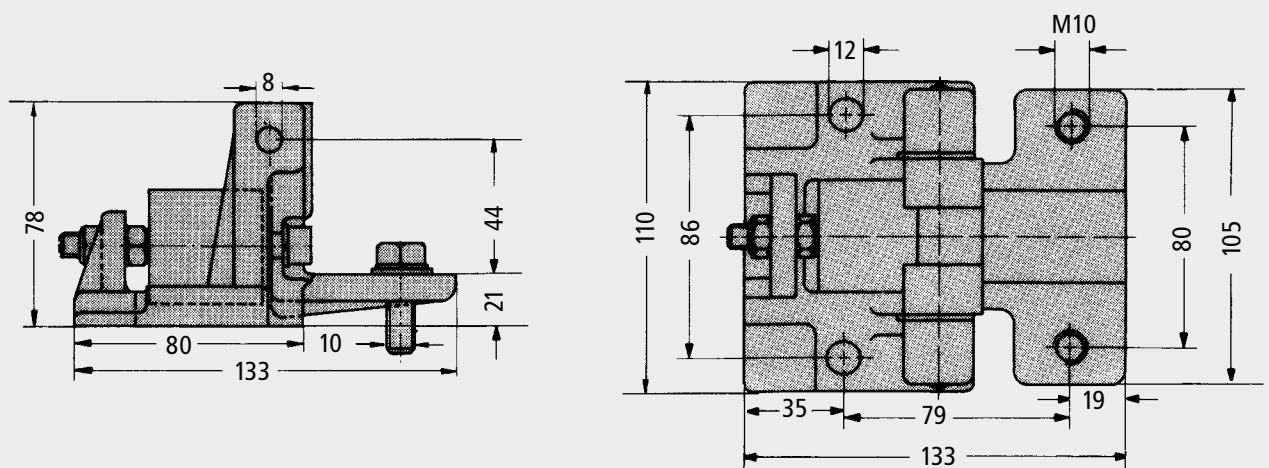

Type G



Type K

The use of the hinge pedestal is recommended to ensure constant pressure between belt and roller in order to avoid failures caused by slip.

The extent of supply of the belt drive comprises rubber or plastic rollers.

Vossloh Kiepe GmbH

D-40599 Düsseldorf (Germany) · Kiepe-Platz 1
Phone +49(0)211 74 97-0 · Fax +49(0)211 74 97-420
info@vkd.vossloh.com · www.vossloh-kiepe.com