

Standstill Monitor

Electro-Mechanical Operated Rotation Sensor

Leaflet No. Kiepe 126



APPLICATION

These robust units are designed to detect shaft rotation, stoppage or reversal and have applications in all industries employing rotating machinery.

Their high reliability and negligible maintenance requirements make them especially suited to materials handling systems in continuously operating plants.

OPERATION

The rotation sensor incorporates a magnetic slip coupling which induces rotation in a further magnet enclosed in a liquid filled capsule. This carries the contact operating pin. As the shaft rotates, the operating pin moves one or the other contact depending upon the direction of rotation.

The exact point of contact operation depends upon the selection of magnetic and fluid couplings and the adjustment of contact spring pressure.

Increase of speed above the operating point causes the magnetic and fluid couplings to „slip” without reducing contact pressures. This makes the unit suitable for low speed detection and high speed continuous operation without damage.

Rotation sensors are suitable for direct drive from rotating shafts. However, they must not be subject to end thrust or excessive vibration. The three couplings shown in this leaflet are especially recommended to cater for shaft misalignment and also to simplify installation.

Where direct drive is not possible the sensors may be driven by belt or chain drive; in this case the heavy duty bearing version should be used to cater for the additional side thrust.

For conveyors the belt drive unit type „B” may be used. This is driven by a plastic roller in direct contact with a rubber or textile belt. An alternative rubber roller is available for roller conveyors.

WIRING DIAGRAM

A



Contact assembly for clock or anti-clockwise rotation

B

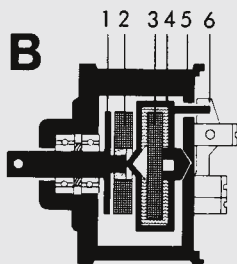

Standstill monitor with magnetic/liquid coupling

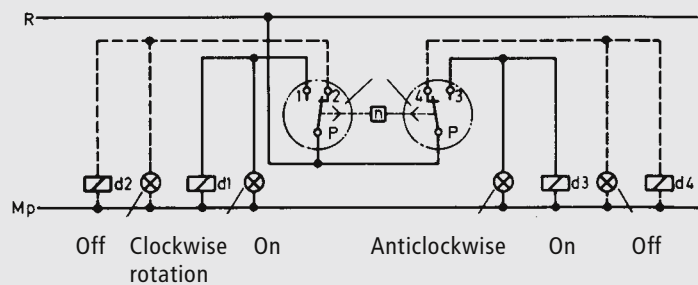

SPEED SELECTION – TYPES AVAILABLE

Type	Typical operation point on falling speed rpm		Typical reset point on rising speed rpm		Minimum running speed rpm	Maximum running speed rpm
	NO	NC	NO	NC		
SW 01	0,5	1	0,75	3	6	3000
SW 02	1	2	1,5	5	10	3000
SW 03	2	4	6	10	20	3000
SW 04	10	15	20	70	100	3000
SW 05	40	70	60	150	200	3000

When used in conjunction with the conveyor monitor type B the operating speed can be converted into rpm by the following formulae:

$$\text{Rev./min.} = \frac{\text{Belt speed in meter/sec.} \times 60}{0,314}$$

MOUNTING BRACKETS AND FLANGES

Type	Order number
Mounting flange F1	96.038 986.003
Mounting flange F2	96.038 986.004
Foot mounting bracket F3	96.038 986.001
Foot mounting bracket F4	96.038 986.002

COUPLINGS

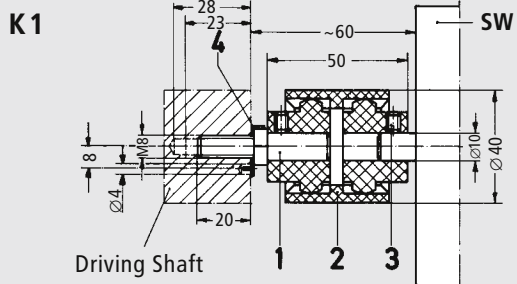

Order number: 94.040 535.001

Flexible plastic coupling
Temperature range about -25 °C ... +100 °C,
weatherproof, maximum misalignment 3 mm

- 1) Connecting shaft
- 2) Coupling
- 3) M5 x 6 grub screw
- 4) 8,4 Locking washer

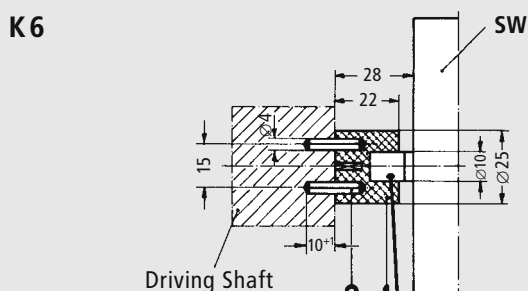

Order number: 96.040 535.002

Two-pin rubber coupling,
oil-resistant, maximum misalignment 2 mm

- 1) Coupling
- 2) Roll pin 4 x 20

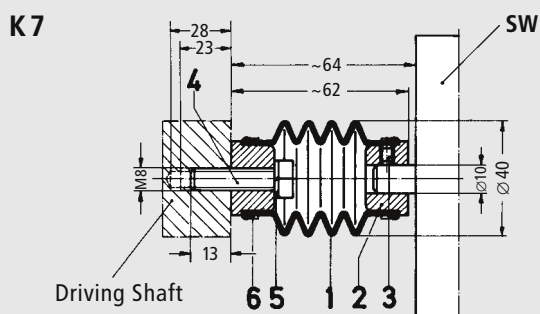
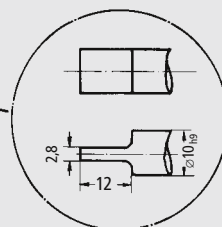

Order number: 94.040 535.004

Flexible bellows coupling suitable for poor misalignment,
maximum misalignment 10 mm

- 1) Bellows
- 2) Fixing collar
- 3) M5 x 6 Grub screw
- 4) Hexagon headed M8 x 3 screw
- 5) Spring retaining ring B 8
- 6) Retaining strap

MOUNTING DETAILS AND ORDERING CODES

SW basic version,
Protection to IP 54

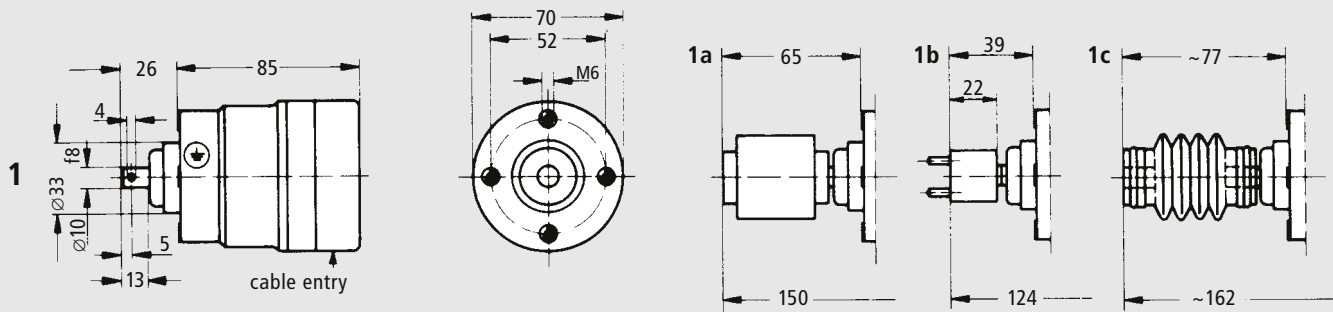

	Type number	Type of casing	Type of mounting	Type of coupling	Order number
1	SW		-1		92.040 580.1
1a	SW		-1	/K1	92.040 580.1
1b	SW		-5	/K6	92.040 580.5
1c	SW		-1	/K7	92.040 580.1

SW basic version with foot mounting bracket F3,
Protection to IP 54

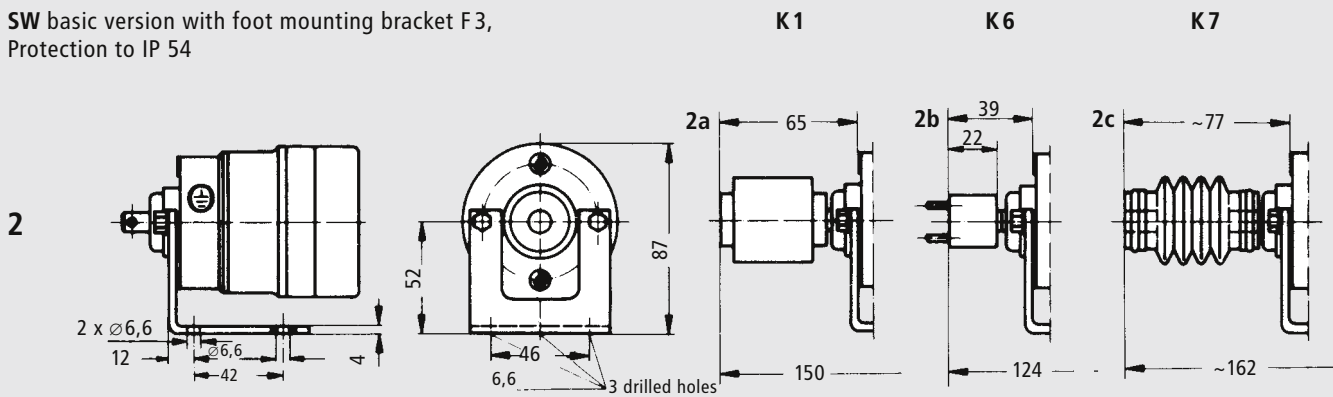

	Type number	Type of casing	Type of mounting	Type of coupling	Order number
2	SW		-1	/F3	
2a	SW		-1	/F3	/K1
2b	SW		-5	/F3	/K6
2c	SW		-1	/F3	/K7

SW in aluminium case type S or SW in cast iron casing GG,
Protection to IP 65

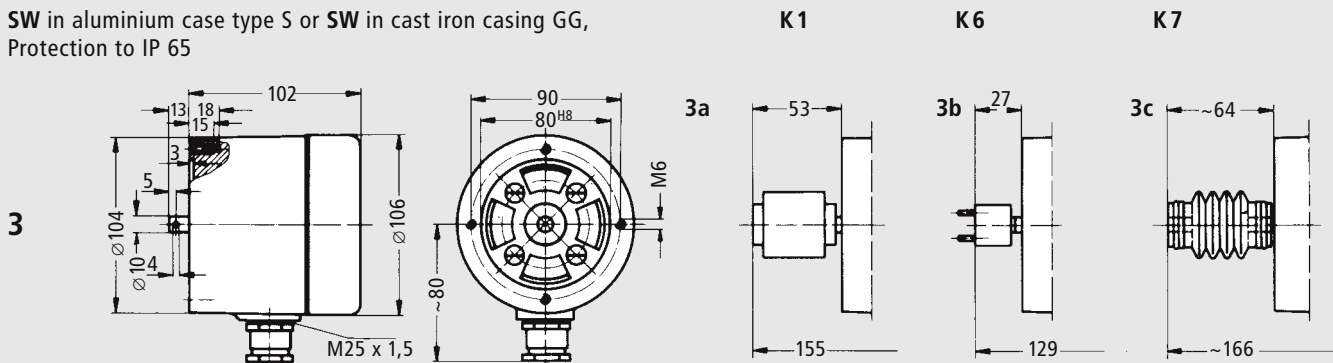

	Type number	Type of casing	Type of mounting	Type of coupling	Order number
3	SW		-2	/S	
3a	SW		-2	/S	/K1
3b	SW		-3	/S	/K6
3c	SW		-2	/S	/K7

MOUNTING DETAILS AND ORDERING CODES

SW in aluminium casing type S with mounting bracket F4,
Protection to IP 65

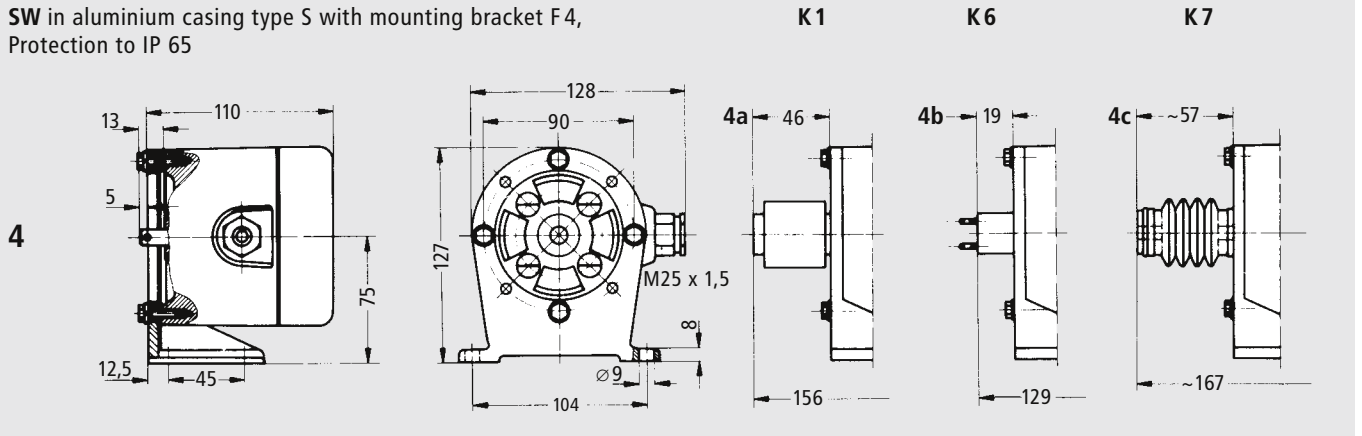

	Type number	Type of casing	Type of mounting	Type of coupling
4	SW	-2 /S	/F4	
4a	SW	-2 /S	/F4	/K1
4b	SW	-3 /S	/F4	/K6
4c	SW	-2 /S	/F4	/K7

SW in aluminium casing type S with mounting flange F1,
Protection to IP 65

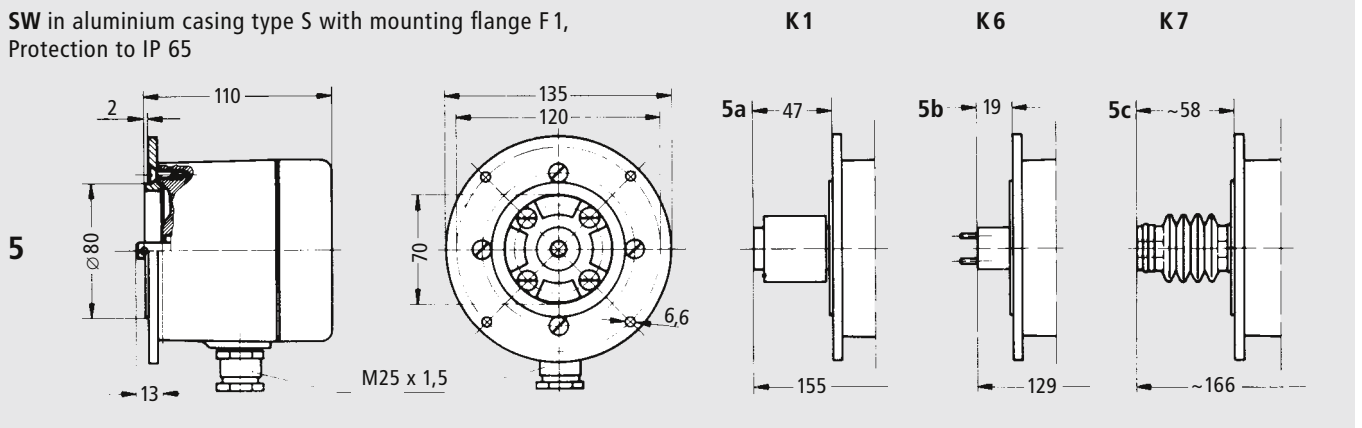

	Type number	Type of casing	Type of mounting	Type of coupling
5	SW	-2 /S	/F1	
5a	SW	-2 /S	/F1	/K1
5b	SW	-3 /S	/F1	/K6
5c	SW	-2 /S	/F1	/K7

SW in aluminium casing type S with extended mounting flange type F2,
Protection to IP 65

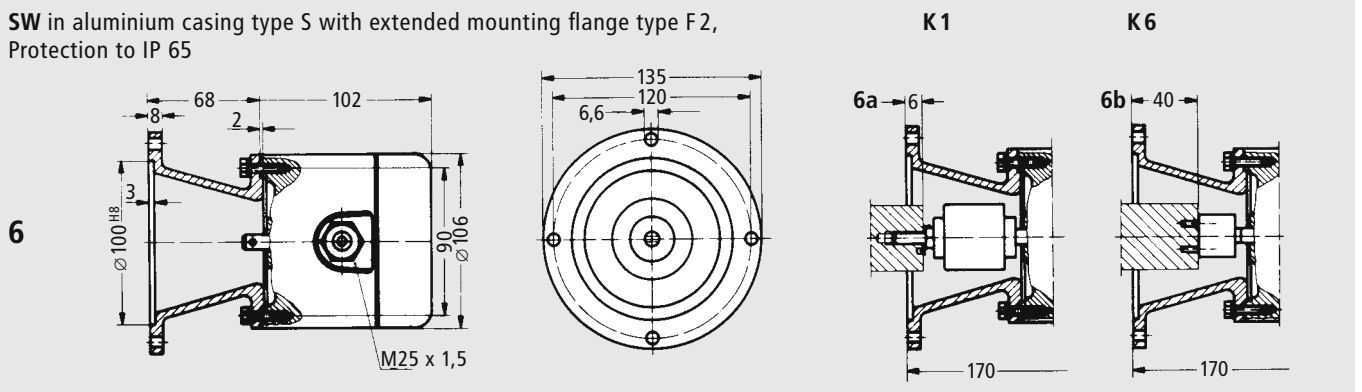

	Type number	Type of casing	Type of mounting	Type of coupling
6	SW	-2 /S	/F2	
6a	SW	-2 /S	/F2	/K1
6b	SW	-3 /S	/F2	/K6

DIMENSIONS AND ORDERING CODES

Standstill Monitors type SWB
with Belt Drive, protected to IP 65

Conveyor Drive Model SWB

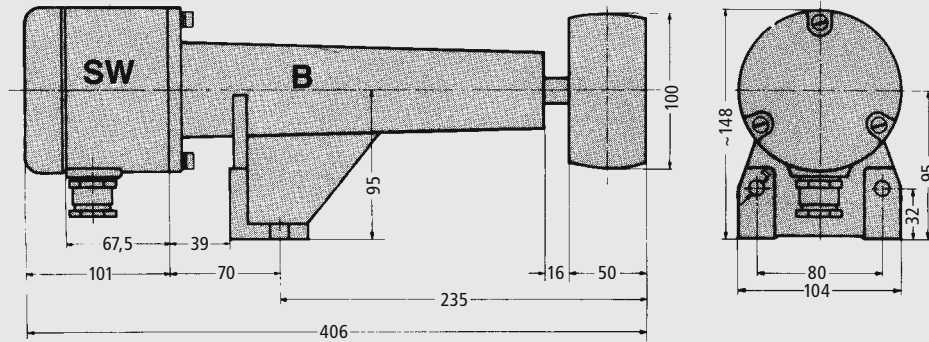

Type number	Housing (IP 65) ¹⁾	Roller ²⁾
SWB	-2 /S	/K
SWB	-2 /S	/G
SWB	-2 /GG	/K
SWB	-2 /GG	/G

¹⁾ S: Aluminium, GG: Cast iron

²⁾ G: Rubber, K: Plastic

DIMENSIONS

Hinge Pedestal Type GB
to be fitted on Belt Drive B

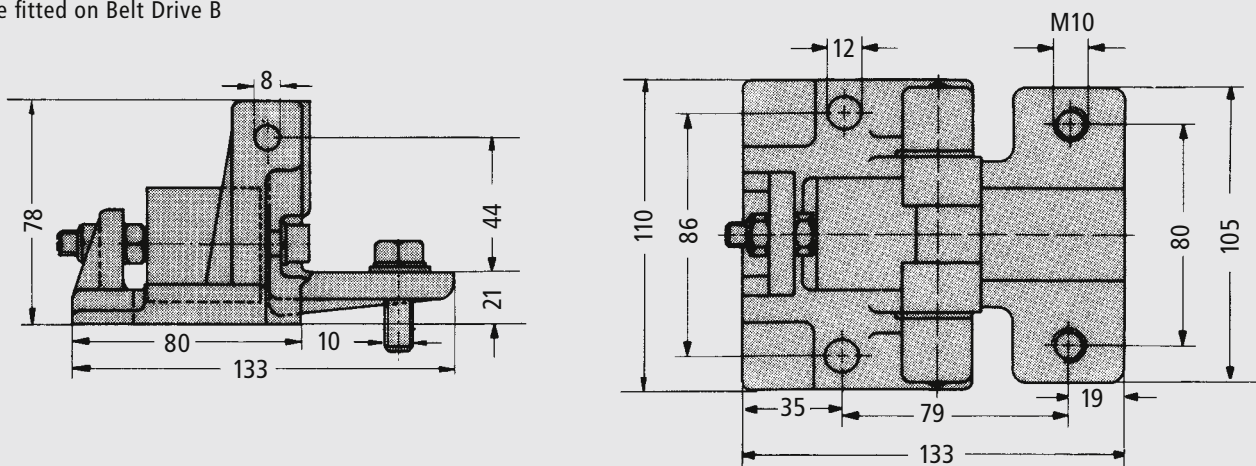

Type G



Type K

The use of the hinge pedestal is recommended to ensure constant pressure between belt and roller in order to avoid failures caused by slip.

The extent of supply of the belt drive comprises rubber or plastic rollers.

Subject to change without notice.

Vossloh Kiepe GmbH

D-40599 Düsseldorf (Germany) · Kiepe-Platz 1
Telefon +49(0)211 74 97-0 · Telefax +49(0)211 74 97-300
info@vkd.vossloh.com · www.vossloh-kiepe.com