

Belt Conveyor Pull Rope Switch

PAS

Leaflet No. Kiepe 511



APPLICATION

Kiepe Pull Rope Switches, type PAS are used in conveyor systems and processing machines. The conveyor or machine can be shut down from all hazard points with one single PAS switch. The maximum length of the rope is 30 m (see attached diagram).

Kiepe Pull Rope Switches and accessories meet the requirements of safety authorities with respect to personnel safety and equipment (VBG 10 / BGI 710).

The device is intended for use in stationary installations and in vehicles.

OPERATION

Kiepe pull rope switches type PAS are actuated by pulling the rope or if the rope is broken or in slack condition. Both NC contacts are hence opened and the switch is mechanically latched.

The reset button indicates the actual switch status (ON/1 or OFF/0).

The conveyor can only be restarted if the mechanical latch has been released by means of the reset button.

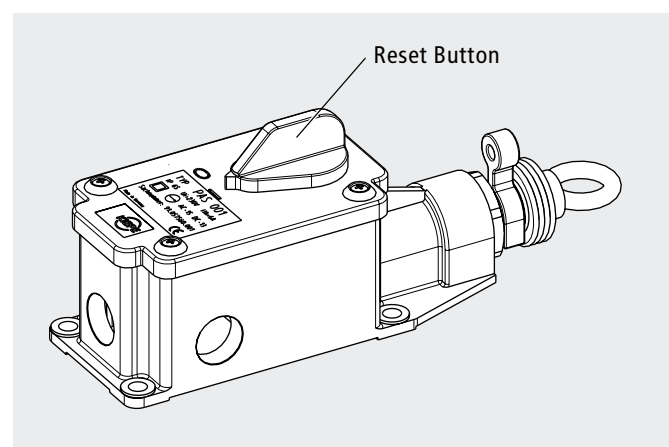

TECHNICAL DATA

In compliance with the following Standards and Regulations	EN 60947-5-1, EN 418 VDE 0110 – Degree of Pollution 2 (interior), 4 (exterior), UVV – VBG 10
Suitable for	Controls and Equipment according to EN 60204
Enclosure	PBT
Finish	Enclosure: yellow (RAL 1004), Reset button: blue (RAL 5010)
Mounting	4 holes for screws M6
Permissible Ambient Temperature (VDE 0660)	$-25\text{ °C} \leq T_{\text{amb}} \leq +70\text{ °C}$
Switching System	1 changeover contact, 2 N.C.-contacts, all switching elements positive making and selfcleaning
Rated Insulation Voltage U_i	250 V
Conventional Thermal Current I_{th}	6 A
Breaking Capacity	AC-15: AC 230 V / 1.5 A, DC-13: DC 60 V / 0.5 A, DC-13: DC 24 V / 2.0 A
IP Protection Class	IP 65 according to EN 60529
Mounting position	any
Cable entry	Tapped hole for 3x M20 x 1.5 1 x cable gland M20 x 1.5; sealing area \varnothing 6 - 12 mm 2 x plug M20 x 1.5
Connections	max. 2.5 mm ²
Actuating Force	approx. 190 N (pretensioning force approx. 110 N)
Weight	approx. 400 g
Ordering Code	91.057560.001

CONTACT ARRANGEMENTS

Connection Diagram

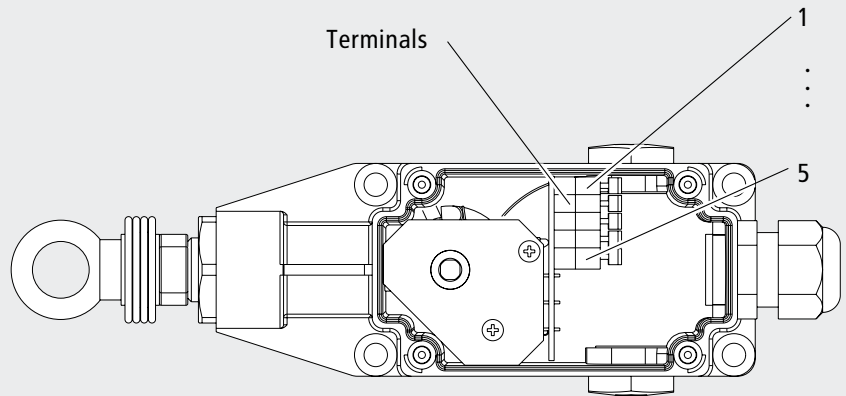
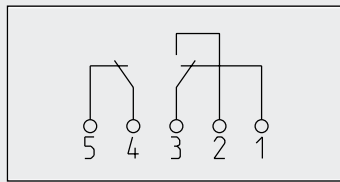

INSTALLATION

For assembling the PAS switch on the conveyor structure please refer to the following sketch.

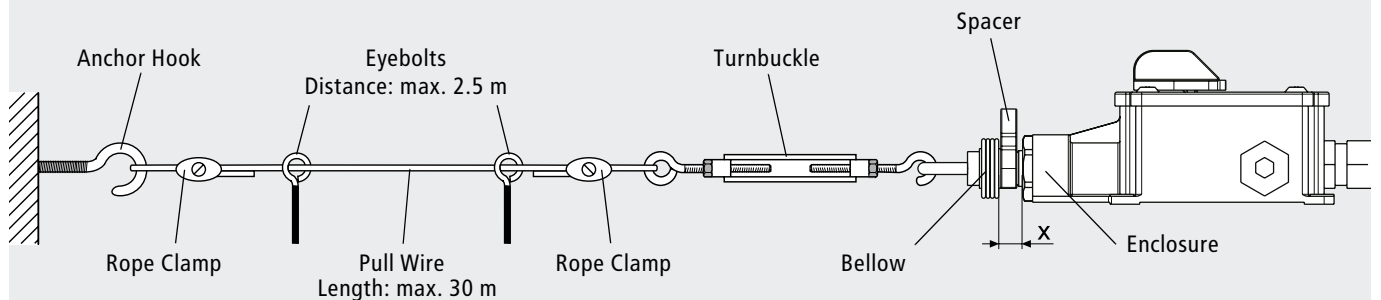

To adjust the correct tension of the rope a spacer is placed between enclosure and bellow.

The pull rope is correctly adjusted if the spacer can easily be removed without any varying of the distance „x“.

LENGTH OF THE ROPE

The max. length of the rope depending on the ambient temperature is shown in the following diagram

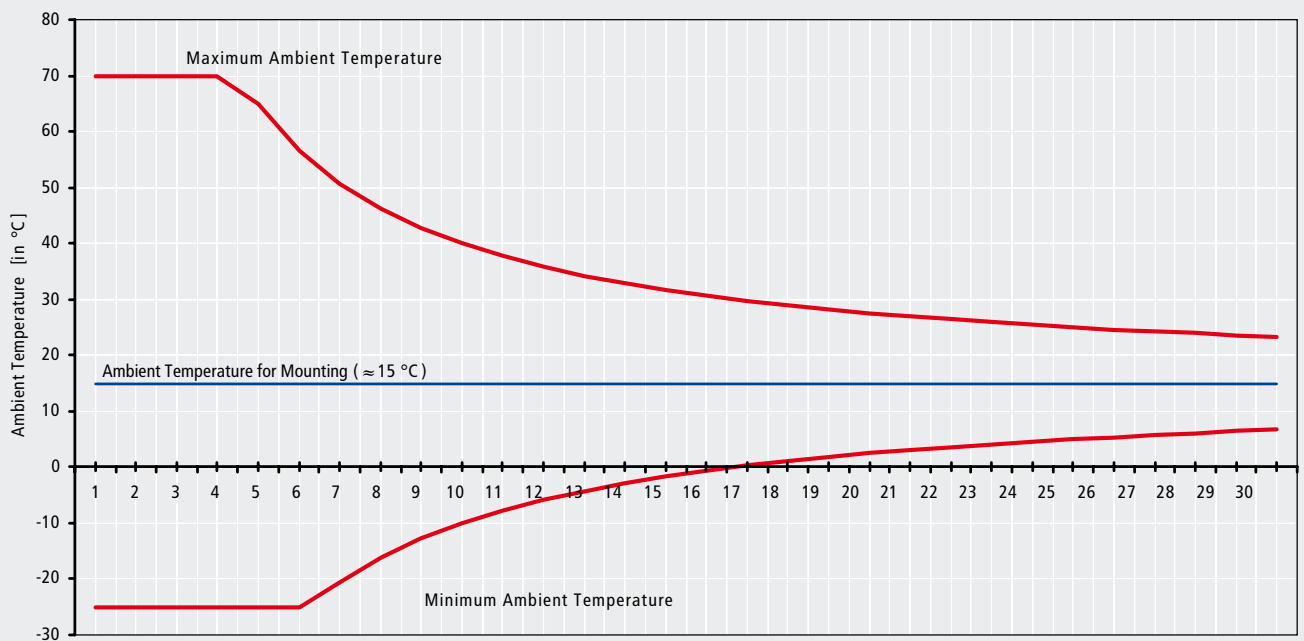

Wire Length for a Pull Wire with a Diameter of 3 mm [in m]

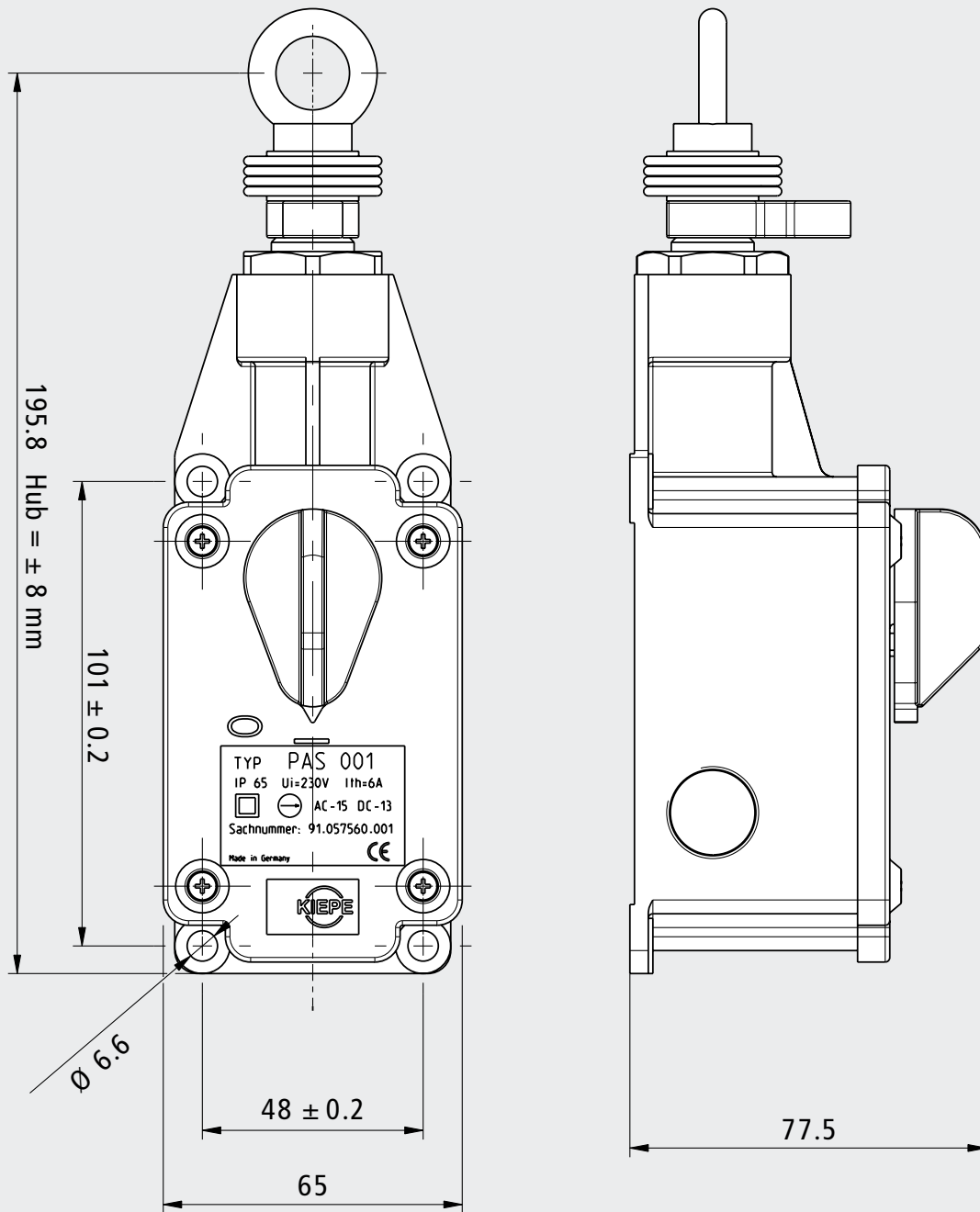

Subject to change without notice.