

Electronic Speed Monitor

JMNC

Leaflet No. Kiepe 220



APPLICATION

The Electronic Speed Monitor relays JMNC is used in connection with a pulse sensor to monitor the rotational speed and standstill of drives.

Pulse sensors according to NAMUR-EN 50227 as well as opto-electronic pulse transducers (Kiepe model EOG) can be connected to the speed monitor relay.

The pulse output is fed to the speed monitor relay where the pulse frequency is compared with the frequency set by the control of the relay. When the input frequency passes the set frequency the internal output relay is switched.

Warning or control equipment can be connected to this output relay and operate when the speed either increases or decreases from the setpoint. The output relay contacts of JMNC are goldplated to improve true contact even in case of low voltage circuit operations.

The operation of the relay can be inhibited during start-up of the monitored drive by adjusting the start-up potentiometer to the time taken for the drive to reach operating speed.

The device is intended for use in stationary installations and in vehicles.

CONSTRUCTION

The control unit JMNC is made of 2 parts. One forms the base and contains a combined edge connector and terminal block, five rubber inserts on three sides for cable entries and two knockout holes in the base are provided for mounting the control unit. The other and main component of the control unit is a printed circuit board which slides into the plastic case and is held in place by a plastic plate which clips into the openside.

The complete plug-in unit is secured to the base by two screws held captive by rubber washers. This arrangement allows withdrawal of the plug-in unit from the base without having to loosen the wiring on the terminal block.

Option

A special design is available to meet requirements where the speed monitor unit should be installed close to the monitored drive and its pulse sensor.

The design consists of speed monitor relay JMNC being installed in a plastic housing, of IP65 protection, and already wired to a terminal block.

The true operation of the device can readily be observed through the transparent cover of the plastic housing.

The features of this arrangement are:

- Shortened length of screened cable between pulse sensor and relay adjustment at commissioning with visual contact to the drive.
- The output signal of the relay can be interference free transmitted to the control equipment without using the screened cable.

OPERATING PRINCIPLE

The circuit arrangement of the speed monitor relay JMNC makes use of the advantages of digital pulse input. There are no time lags normally encountered with analog devices. The unit compares the time between successive input pulses and its preset frequency.

Differences result in immediate switch-off of the output relay. The output relay will switch, too, if the connected pulse sensor becomes damaged or the power supply fails.

SETTING CONTROLS

Start-up delay potentiometer

Operation of the relay can be inhibited during start-up by adjusting the potentiometer over the range of 0 to ≥ 45 sec. depending on the time taken for the monitored drive to reach operating speed.

Pulse range selector switch

The trip point can be adjusted within the range of 8 - 12000 pulses per minute. This total range is divided into 3 continuously adjustable setting ranges.

Pulses /min.	Position of the pulse range switch	Cut-out delay in sec. Pick-up time of relay non considered
8 ... 120	I	7,5 ... 0,5
80 ... 1200	II	0,75 ... 0,05
800 ... 12000	III	0,075 ... 0,005

Please note: The indication beside the pulse range selector switch signifies pulses/min. and not r.p.m..

Pushbutton

Pressing of the pushbutton links the output relay during the adjustment of the trip point and prevents the drive from becoming cut-off during the adjustment.

Setpoint potentiometer, Coarse

provides coarse trip point adjustment.

Setpoint potentiometer, Fine

provides fine adjustment of trip point within the range of 10 % of set coarse adjustment.

LED-diode, green

indicates state of output relay

- LED „lit“ means operating speed above setpoint, output relay energized
- LED „off“ means fault - operating speed below trip point, output relay deenergized

LED-diode, orange

This LED will be lit of flashes according to the received pulses. From 1500 pulses/min. up the flashing will change to a continuous light. If the speed monitor relay is under operation, but the orange LED remains to be off (out), either the pulse transducer or the wiring between sensor and relay unit fails.

TECHNICAL DATA

Device complies with	EN 50178-94 EN 50081-1 EN 50082-2 EN 60204
Operating Principles	Underspeed or standstill
Mechanical	The plug-in base is resistant to tracking and houses the cable entries and connection terminals. The housing contains the plug-in PCB.
Actuating Supply Voltages	AC 230 V, 50 ... 60 cyc., other voltages by request.
Voltage Tolerance	± 10 %
Power Consumption	Approx. 2.5 VA
Ambient Temperature	-25 °C ... +70 °C
Storage Temperature	-35 °C ... +80 °C
Trip Point Accuracy	< 1 % (at constant temperature)
Reset Differential	10 % at pre-set speed
Pulse Duration	≥ 1.5 ms
Pick-up Time	For the internal output relay of the Speed Monitor unit with starting by-pass it is 150 ms after having connected the JMNC to the actuating supply voltage.
Starting By-pass	0 - 45 sec. adjustability
Protection	IP 51 (dust and drip-proof) according to EN 60529
Mounting Position	Vertical
Output Contact	1 changeover contact
Contact ratings I_e/U_e	AC 2 A/230 V

SWITCHING CHARACTERISTIC

Speed Monitor Relay type JMNC (underspeed monitoring)

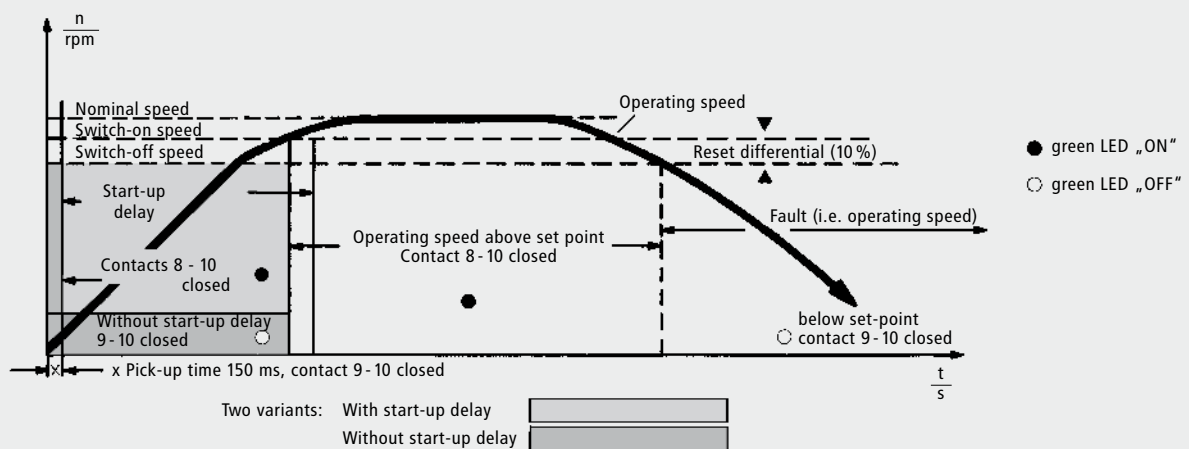

OPERATIONS

Monitoring of underspeed or standstill with start-up delay

Adjust the potentiometer to the required start-up delay-time. The internal output relay is energized during the start-up time (contact 8 - 10 closed).

The relay will be cut off if the operating speed is below the trip point (contacts 9 - 10 closed).

Note: In addition, if it is necessary to monitor pulse failure, the Kiepe speed monitor model EDO should be used.

Monitoring of overspeed (maximum speed) without start-up delay

Set the start-up potentiometer to zero (fully left). The internal output relay will be energized (contact 10 - 8, closed) as soon as the operating speed is higher than the adjusted setpoint.

CONNECTION SAMPLES

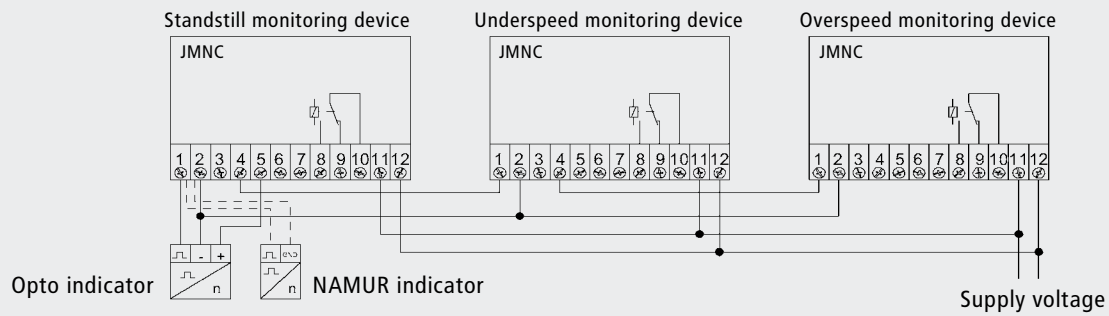

Example: Several rotational speed monitoring devices JMNC connected to one pulse indicator.

DIMENSIONS

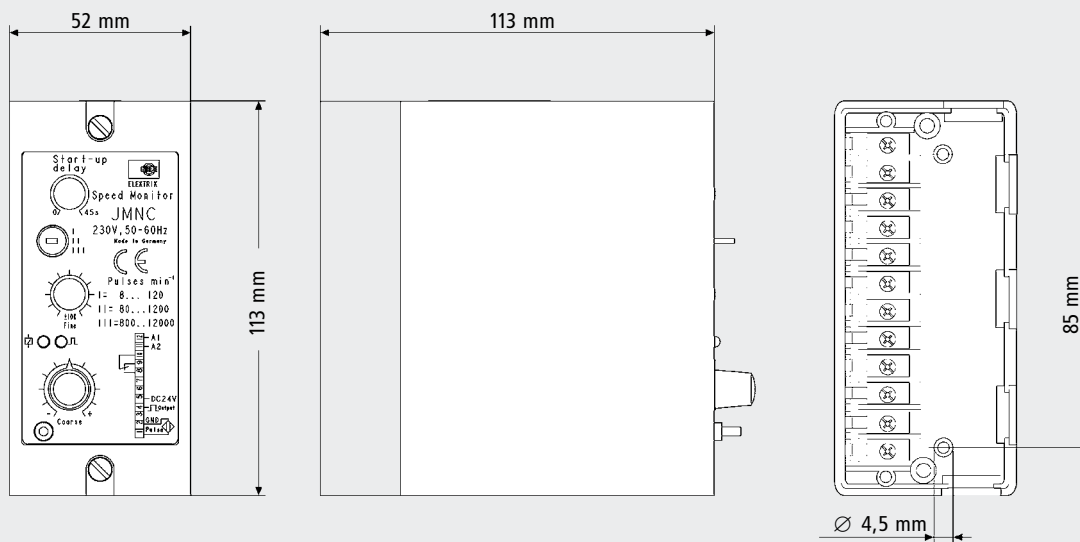

Subject to change without notice.