

Belt Conveyor Pull Rope Switch

HEN 201

with Dupline-bus terminal

Leaflet No. Kiepe 472



APPLICATION

Kiepe Pull Rope Switches HEN provide a switching system to isolate the power to conveyor systems and other process equipment in event of an emergency. The devices have been designed for a maximum of safe operation under severe conditions.

Kiepe Pull Rope Switches and accessories meet the requirements of international safety standards with respect to personnel safety and equipment.

The device is intended for use in stationary installations and in vehicles.

MONITORING

In addition to the emergency cut-out function the HEN 201 provides a Dupline field and installation bus node of the Carlo Gavazzi company. The Dupline system offers an economic solution to locate actuated pull rope switches within large conveying systems.

Up to 128 independent signals can be transmitted via merely two wires of the Dupline bus towards any direction over several kilometres.

The Dupline bus is a pure information bus and not a safety bus. Switching off a conveyor must be realized by disconnecting the safety circuit via positive making switching elements.

OPERATION

Kiepe Pull Rope Switches are actuated by a plastic coated steel wire rope placed along-side the conveyor. Pulling on the rope at any point will trip and automatically lock the switches, de-energizing the conveyor starter contactor.

Each switch is bi-directional in operation and has two ropes fitted to it from opposite directions terminating with a spring at the anchor points. The springs will operate the switch in the event of rope breakage. The length of rope in either direction may be up to 50 meters. After tripping, the mechanical latch can be released only on the switch itself.

To shorten installation work both circuits can be run in one cable. By means of a manual coder an address will be applied to each pull rope switch.

The channel generator continuously transmits the digital pulse code (the Dupline carrier signal) to the Dupline network. It synchronises the system via the clock pulse and time control of all bus participants connected to the system. It enables the connection to all important upper-level control systems, e.g. Profibus-DP, DeviceNet and others.

TECHNICAL DATA

Device complies with	EN 60947-5-1 EN 418 VDE 0110 UVV-VBG 10 EN 60204
Housing	Aluminium GK-ALSi12
Finish	2-component DD-tile enamel Enclosure yellow, RAL 1004 Actuating lever red, Ral 3000 Reset lever blue, RAL 5010
Mounting	2 bolts M8
Ambient Temperature	-25 °C ... +70 °C
Protection	IP 65 according to EN 60529
Switching System	2 positive making NC-contacts for emergency cut off
Rated Insulation Voltage U_i	AC 380 V
Rated Operational Voltage U_e	AC 240 V
Conventional Thermal Current I_{th}	16 A
Breaking Capacity I_e/U_e	AC 10 A/230 V
Connection	max. 2,5 mm ²
Cable Entry	3 x M25 x 1,5
Bus Terminal	
Operating Voltage	via Dupline bus
Nominal Current Consumption	with LED switched off: typ. 150 µA with LED switched on: typ. 1,2 mA
Order Number	91.043 450.201

CONNECTING DIAGRAM OF THE DUPLINE-PCB

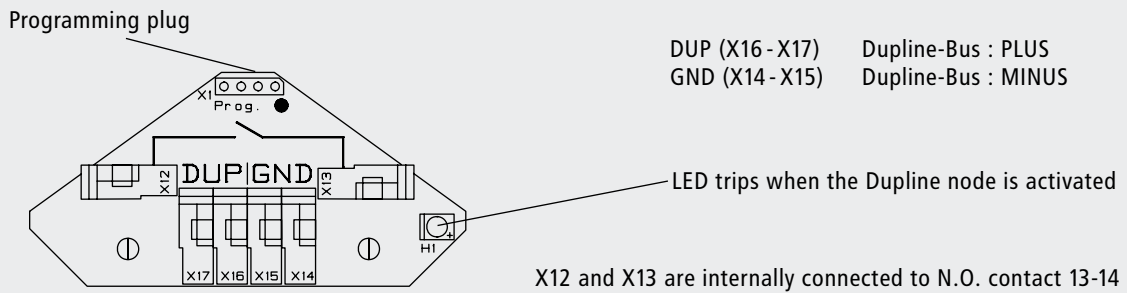

ACCESSOIRES

Pull rope, flexible steel wire, plastic coated, \varnothing 3 mm red color, (available in 50, 100 or 500 m length)	94.045 731.001
Tension spring, stainless steel, 170 mm x \varnothing 20 mm	94.000 026.681
Turnbuckle (metal, 1 hook, 1 eye)	215.22.80.02.01
Rope clamp, egg form	94.047 869.001
Eyebolt M 12 x 60	94.045 727.001
Eyebolt M 12 x 200	94.045 727.002
Swing hook M 10	94.045 728.001

INSTALLATION

The switches are easily installed along the edge of the conveyor structure. The actuating lever should be positioned adjacent to the belt edge with the reset lever on the outside. Flexible vinyl coated steel wire is available for the pull rope. One egg formed clamp is used for each rope fastening point. For guiding and rope support eyebolts are used at intervals up to 2,5 m. Stainless steel springs at the end of the rope ensure operation of the switch in the event of rope breakage (Fail safe).

The spring pretension is adjusted by means of turnbuckles which can simply be attached onto the actuating lever. Since the switches are bi-directional in operation, variations of temperature which can influence the rope length become balanced by means of the two springs.

ADJUSTMENT

1. Install the pull rope on one side of the actuating lever according to the drawing below.
2. Adjust the rope tension in such a way that the spring will properly operate the switch. Maximum extension of the spring is 500 mm. Now detach again the turnbuckle.
3. Repeat procedure 1. and 2. on the other side.
4. Attach both turnbuckles and operate the switch.
5. The now movable actuating lever should be balanced in the mid position by means of the two turnbuckles.
6. To limit the actuating distance of the pull rope and to avoid an inadmissible extension of the spring, a rope loop of approx. 40 to 60 mm longer than the tensioned spring should be installed in a parallel position.

7. Reset the switch. The system is now ready for operation.

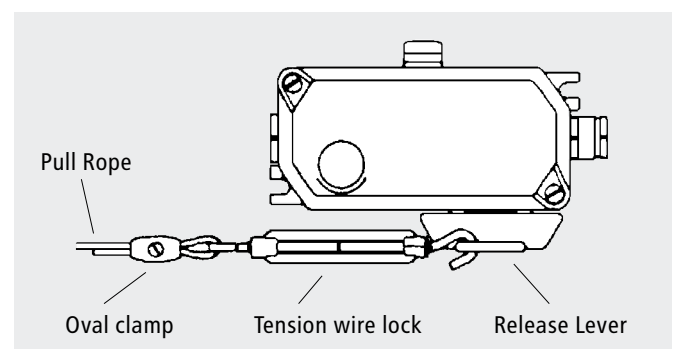

INSTALLATION

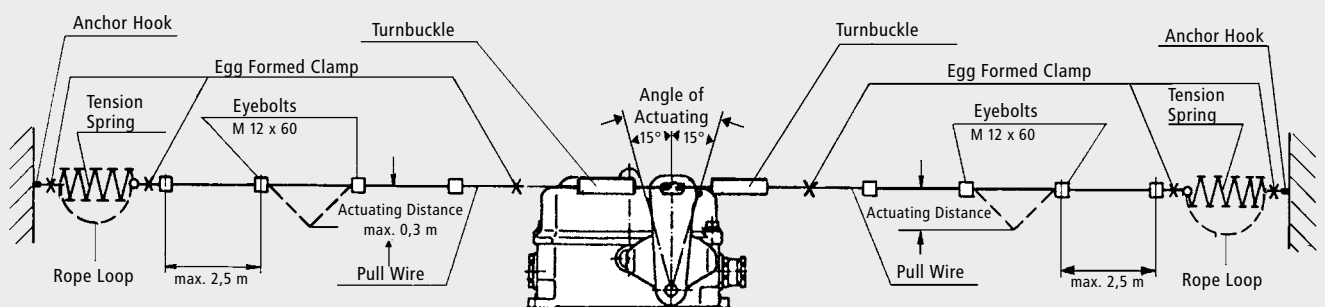

DIMENSIONS

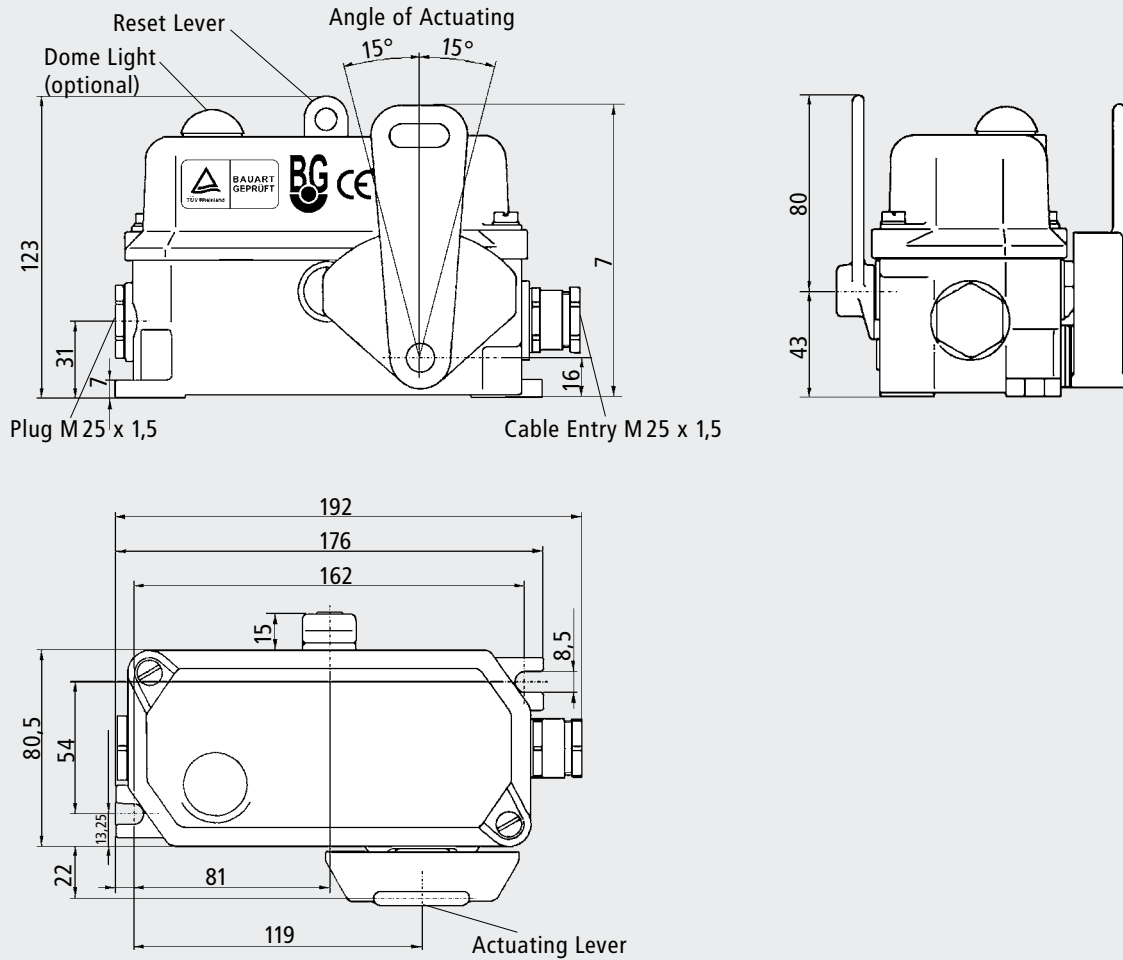

CONTACT ARRANGEMENTS

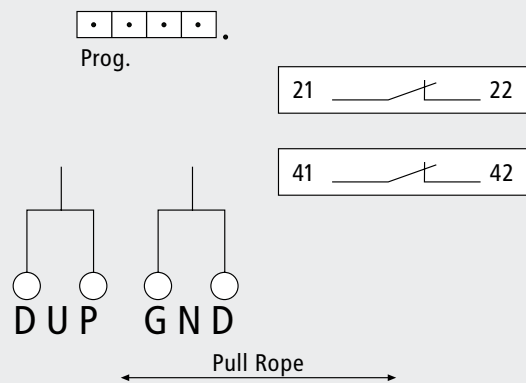

Subjects to change without notice.