

## *VeriSens*<sup>®</sup> Serie 1000

Universal vision sensors for automation technology

### For inspection of

- Part completeness
- Part presence
- Part location
- Correct position

### Sensor Solutions

Motion Control

Vision Technologies

Process Instrumentation

Models	VXS 1003M10RS	VXS 1003M10WS	VXS 1003M16RS	VXS 1003M16WS
Image sensor	High Sensitive Progressive Scan CCD			
Number of pixels	656 x 494			
Type	Monochrome			
LED illumination	Red (typ. 660 nm)	White	Red (typ. 660 nm)	White
Speed	High Resolution Mode: max. 30 inspections per second High Speed Mode: max. 50 inspections per second			
Lens	f = 10 mm		f = 16 mm	
Min. object distance	50 mm		60 mm	
Object distance	Maximum field of view			
60 mm	30 mm x 23 mm		13 mm x 10 mm	
100 mm	51 mm x 38 mm		26 mm x 20 mm	
200 mm	101 mm x 76 mm		57 mm x 43 mm	
300 mm	152 mm x 114 mm		89 mm x 67 mm	
Signal processing	Baumer FEX® 3.0			
Processor	Baumer FEX® 3.0			
Memory	64 MBytes			
Inputs / Outputs	Inputs: 8...30 VDC / Outputs: PNP 100 mA			
3x digital input	Trigger			
	Job selection 1			
	Job selection 2 / external Teach-in			
3x digital output	Ready			
	Pass / Fail			
	Flash sync / Alarm			
Communication	USB 2.0			
Serial	USB 2.0			
Electrical data	8...30 VDC			
Power supply	8...30 VDC			
Power consumption	Typical 6 Watts			
Housing	Aluminum and PMMA			
Material	Aluminum and PMMA			
Weight	250 g			
Operating conditions	5 °C...50 °C			
Operating temperature	5 °C...50 °C			
Humidity	0 %...90 % (non-condensing)			
Protection class	IP 64			

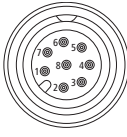
PLC interface	Type M12 / 8-pin
1: IN1 (Trigger)	
2: Power + 24 VDC	
3: OUT1 (Ready)	
4: OUT2 (Pass / Fail)	
5: OUT3 (Flash / Alarm)	
6: IN2 (Job)	
7: Ground	
8: IN3 (Job / Teach)	

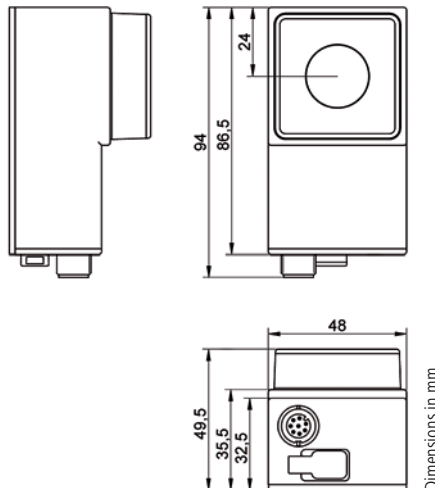

## Series 1000

### Your benefits

- Powerful, two-dimensional position correction for object detection
- Multiple applications are feasible due to extensive function library from brightness sensing to contour sensing
- Reliable operation even under varying lighting conditions due to contour-based image processor
- Rapid commissioning is supported by intuitive user interface with pre-configured sensor functions
- Capable of switching between up to 255 jobs
- Compact
- Reliable
- Powerful
- User-friendly



# Baumer

Baumer Switzerland

Baumer Group · International Sales  
P.O. Box · Hummelstrasse 17 · CH-8501 Frauenfeld  
Phone +41 (0)52 728 1122 · Fax +41 (0)52 728 1144  
sales@baumergroup.com · www.baumergroup.com

Find your local partner

[www.baumergroup.com/worldwide](http://www.baumergroup.com/worldwide)